



PUBLIC NOTICE

US Army Corps
of Engineers
New York District
Jacob K. Javits Federal Building
New York, N.Y. 10278-0090
ATTN: Regulatory Branch

In replying refer to:
Public Notice Number: **NAN-2016-01044-WCA**
Issue Date: **October 25, 2016**
Expiration Date: **November 23, 2016**

To Whom It May Concern:

The New York District, Corps of Engineers has received an application for a Department of the Army permit pursuant to Section 10 of the Rivers and Harbors Act of 1899 (33 U.S.C. 403), and Section 404 of the Clean Water Act (33 U.S.C. 1344).

APPLICANT: New Jersey Dept. of Environmental Protection
Office of Resource Development
275 Freehold-Englishtown Road
Englishtown, New Jersey 07726

ACTIVITY: Perform ferry terminal rehabilitation activities and dredging with upland disposal within six ferry slips located at the Liberty State Park Ferry Terminal.

WATERWAY: Hudson River

LOCATION: City of Jersey City, Hudson County, New Jersey.

A detailed description and plans of the applicant's activity are enclosed to assist in your review.

The decision whether to issue a permit will be based on an evaluation of the probable impact including cumulative impacts of the proposed activity on the public interest. That decision will reflect the national concern for both protection and utilization of important resources. The benefit which reasonably may be expected to accrue from the proposal must be balanced against its reasonably foreseeable detriments. All factors which may be relevant to the proposal will be considered including the cumulative effects thereof; among those are conservation, economics, aesthetics, general environmental concerns, wetlands, historic properties, fish and wildlife values, flood hazards, floodplain values, land use, navigation, shoreline erosion and accretion, recreation, water supply and conservation, water quality, energy needs, safety, food and fiber production, mineral needs, considerations of property ownership and, in general, the needs and welfare of the people.

The Corps of Engineers is soliciting comments from the public; Federal, state, and local agencies and officials; Indian Tribes; and other interested parties in order to consider and evaluate the impacts of this proposed activity. Any comments received will be considered by the Corps of Engineers to determine whether to issue, modify, condition or deny a permit for this proposal. To make this decision, comments are used to assess impacts on endangered species, historic properties, water quality, general environmental effects, and the other public interest factors listed above. Comments are used in preparation of an Environmental Assessment and/or an Environmental Impact Statement pursuant to the National Environmental Policy Act. Comments are also used to determine the need for a public hearing and to determine the overall public interest of the proposed activity.

CENAN-OP-RW
PUBLIC NOTICE NO. NAN-2016-01044-WCA

ALL COMMENTS REGARDING THE PERMIT APPLICATION MUST BE PREPARED IN WRITING AND MAILED TO REACH THIS OFFICE BEFORE THE EXPIRATION DATE OF THIS NOTICE, otherwise, it will be presumed that there are no objections to the activity.

Comments submitted in response to this notice will be fully considered during the public interest review for this permit application. Comments provided will become part of the public record for this permit application. All written comments, including contact information, will be made a part of the administrative record, available to the public under the Freedom of Information Act. The Administrative Record, or portions thereof, may also be posted on a Corps of Engineers internet web site. Due to resource limitations, this office will normally not acknowledge the receipt of comments or respond to individual letters of comment.

Any person may request, in writing, before this public notice expires, that a public hearing be held to collect information necessary to consider this application. Requests for public hearings shall state, with particularity, the reasons why a public hearing should be held. It should be noted that information submitted by mail is considered just as carefully in the permit decision process and bears the same weight as that furnished at a public hearing.

Our preliminary determination is that the activity for which authorization is sought herein is not likely to affect any Federally endangered or threatened species or their critical habitat. However, pursuant to Section 7 of the Endangered Species Act (16 U.S.C. 1531), the District Engineer is consulting with the appropriate Federal agency to determine the presence of and potential impacts to listed species in the project area or their critical habitat.

The Magnuson-Stevens Fishery Conservation and Management Act, as amended by the Sustainable Fisheries Act (Public Law 104-267), requires all Federal agencies to consult with the National Oceanic and Atmospheric Administration Fisheries Service (NOAA/FS) on all actions, or proposed actions, permitted, funded, or undertaken by the agency, that may adversely affect Essential Fish Habitat (EFH). The proposed work, fully described in the attached work description, could cause the disruption of habitat for various life stages of some EFH-designated species. Further consultation with NOAA/FS regarding EFH impacts and conservation recommendations is being conducted and will be concluded prior to the final decision.

Based upon a review of the latest published version of the National Register of Historic Places, the Liberty State Park Ferry Terminal is listed in the National Register of Historic Places, and is incorporated in the listing for the "Central Railroad of New Jersey Terminal (ID#1513). Presently unknown archeological, scientific, prehistorical, or historical data may be lost by work accomplished under the required permit.

Reviews of activities pursuant to Section 404 of the Clean Water Act will include application of the guidelines promulgated by the Administrator, U.S. Environmental Protection Agency, under authority of Section 404 (b) of the Clean Water Act and the applicant will obtain a water quality certificate or waiver from the appropriate state agency in accordance with Section 401 of the Clean Water Act prior to a permit decision.

Pursuant to Section 307 (c) of the Coastal Zone Management Act of 1972 as amended [16 U.S.C. 1456 (c)], for activities under consideration that are located within the coastal zone of a state which has a federally approved coastal zone management program, the applicant has certified in the permit application that the activity complies with, and will be conducted in a manner that is consistent with, the approved state coastal zone management program. By this public notice, we are requesting the state's concurrence with, objection to, or waiver of the applicant's certification. No

CENAN-OP-RW
PUBLIC NOTICE NO. NAN-2016-01044-WCA

permit decision will be made until one of these actions occurs. For activities within the coastal zone of New Jersey State, the applicant's certification and accompanying information is available from the New Jersey Department of Environmental Protection, Coastal Management Program, P.O. Box 418, 401 E. State Street, Trenton, NJ, 08625, Telephone (609) 633-2201. Comments regarding the applicant's certification, and copies of any letters to this office commenting upon this proposal, should be so addressed.

In addition to any required water quality certificate and coastal zone management program concurrence, the applicant has obtained or requested the following governmental authorization for the activity under consideration:

- (New Jersey Department of Environmental Protection Waterfront Development Permit)

It is requested that you communicate the foregoing information concerning the activity to any persons known by you to be interested and who did not receive a copy of this notice. If you have any questions concerning this application, you may contact this office at (917) 790-8412 and ask for Jim Cannon.

In order for us to better serve you, please complete our Customer Service Survey located at <http://www.nan.usace.army.mil/Missions/Regulatory/CustomerSurvey.aspx>.

For more information on New York District Corps of Engineers programs, visit our website at <http://www.nan.usace.army.mil>.



For and in behalf of

Stephan A. Ryba
Chief, Regulatory Branch

Enclosures

WORK DESCRIPTION

The applicant, the New Jersey Department of Environmental Protection, Office of Resource Development, has requested Department of the Army authorization to dredge with upland disposal and rehabilitate six (6) existing ferry slips located at the Liberty State Park Ferry Terminal, within the Hudson River, in the City of Jersey City, Hudson County, New Jersey.

The existing Liberty State Park Ferry Terminal consists of six (6) ferry slips with five (5) associated ferry rack structures. There are two (2) exterior ferry slips for side loading (north and south) and four (4) interior slips for bow loading.

Regulated Ferry Terminal Rehabilitation Activities: The applicant proposes to remove, waterward from the existing bulkhead, all existing deteriorated timber structures and substructures associated with ferry slips 3, 4, and 5, including their associated deteriorated buffer and spring platform structures; timber decking; transfer bridges; concrete gravity walls and concrete slabs, as well as their associated timber fender racks. Fender rack number 1, with its associated buffer and spring platform structures would remain as existing. The fender rack structure associated with ferry slip 2 would remain as existing, but its associated buffer and spring platform structures; associated timber decking; concrete gravity walls, and concrete slabs would be removed and rehabilitated. The deteriorated ferry terminal structures would be replaced (within the same footprint) with modern materials that provide the same general appearance and design (and square footage) as the existing ferry slips to ensure the historic look of the facility. The proposed ferry slip reconstruction would consist of steel pipe piles with precast concrete pile caps and precast concrete deck slabs.

The existing deteriorated remains of the transfer bridges situated within ferry slips 1, 2, 3, and 4 would be replaced and would consist of heavy timber and steel framing with four (4) built-up top chord bowstring vierendeel trusses that would support the bridge decks. As part of the proposed rehabilitation activities, a new 40-foot long by 40-foot wide loading barge, secured by six (6) 36-inch diameter steel spud piles, with an associated 40-foot long by 8-foot wide aluminum access ramp would be installed within ferry slips 1, 2, 3, and 4.

Dredging Activities: The applicant proposes to dredge, by closed clamshell bucket, and with upland disposal, a total of approximately 20,600 cubic yards of material from the six ferry slips. Each of the six ferry slips would be dredged to a depth of -15 feet below the plane of Mean Low Water (MLW) plus 2 foot overdepth to -17 feet below the plane of MLW. The dredged material would be loaded into sealed barges, and the decanting of excess water would be performed in accordance with the requirements of the water quality certificate issued by the New Jersey Department of Environmental Protection for the project. The applicant intends to seek an Acceptable Use Determination from the New Jersey Department of Environmental Protection Office of Dredging and Technology in order to dispose of the dredged material at a state approved upland site. The applicant has stated that the proposed duration of the dredging activities would be approximately twelve (12) weeks. The proposed dredging activities would occur adjacent to the Hudson River Federal Navigation Channel. The Liberty State Park Ferry Terminal is approximately 425 linear feet from the Federal Navigation Channel of the Hudson River.

The stated purpose of the project is to provide continued safe navigation for tourist and commuter ferries accessing the Liberty State Park Ferry Terminal.

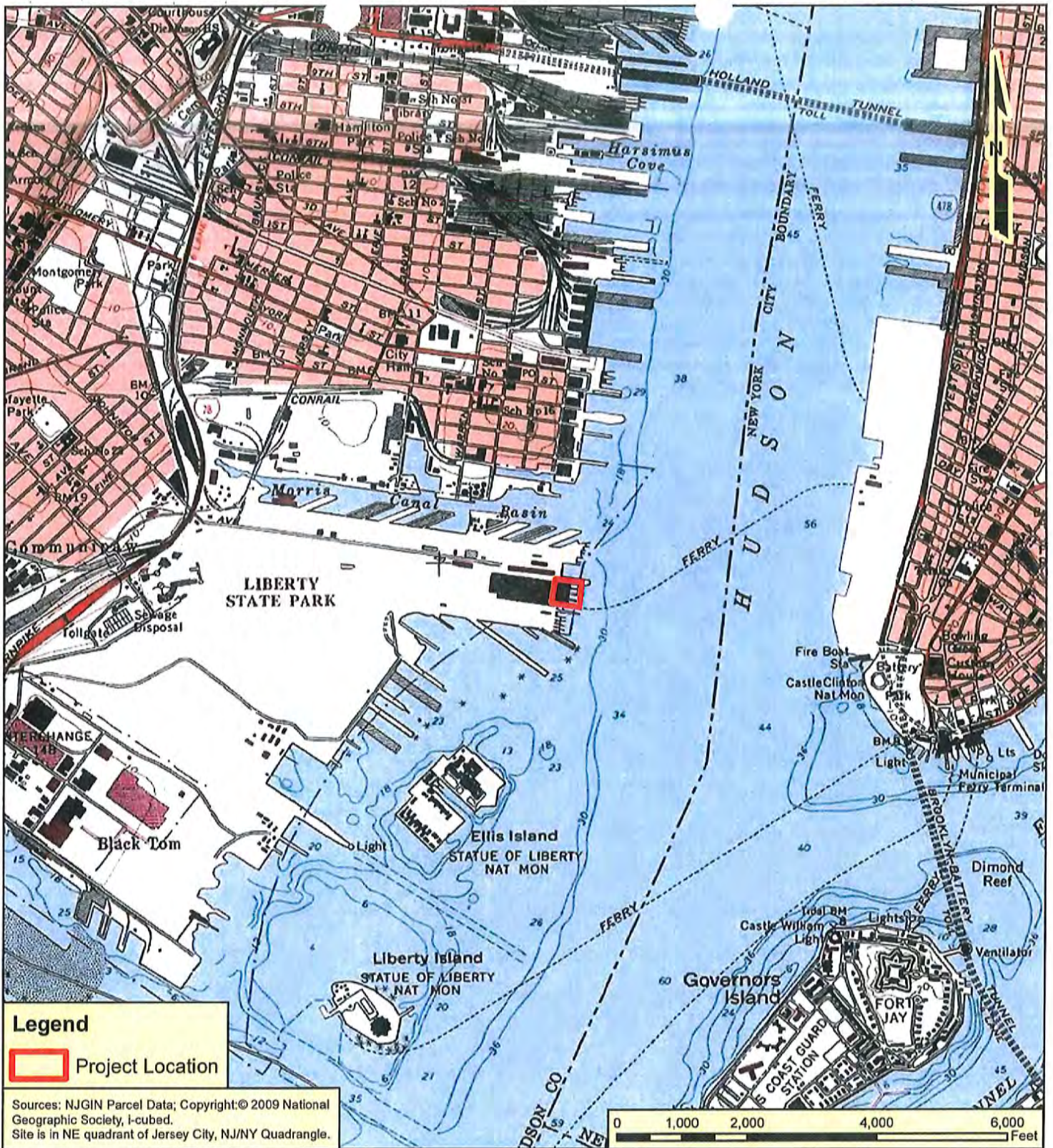

Legend

Project Location

Sources: NJGIN Parcel Data; Copyright: © 2009 National Geographic Society, I-cubed.
 Site is in NE quadrant of Jersey City, NJ/NY Quadrangle.

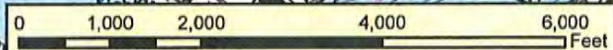

USGS TOPO SITE LOCATION MAP

MATRIXNEWORLD

Enabling Progress

Matrix New World Engineering, Inc.
 26 Columbia Turnpike
 Florham Park, New Jersey 07932
 WBE / DBE / SBE

Tel: 973-240-1800
 Fax: 973-240-1818
 www.matrixnewworld.com

**LIBERTY STATE PARK
 FERRY SLIP RECONSTRUCTION
 CITY OF JERSEY CITY
 HUDSON COUNTY, NEW JERSEY**

SCALE: 1:24,000

1 inch = 2,000 feet

DATE:

OCTOBER 2015

JOB NO.:

15-296

DRAWN BY:

KCW

FIGURE NO.:

1 of 20

I:\matrix-data\share\sta\15115-296_CRRNJ_Terminal_Bldg_Liberty_State_Park\GIS\Images\USGS_Topo_Site_Location_Mao.mxd

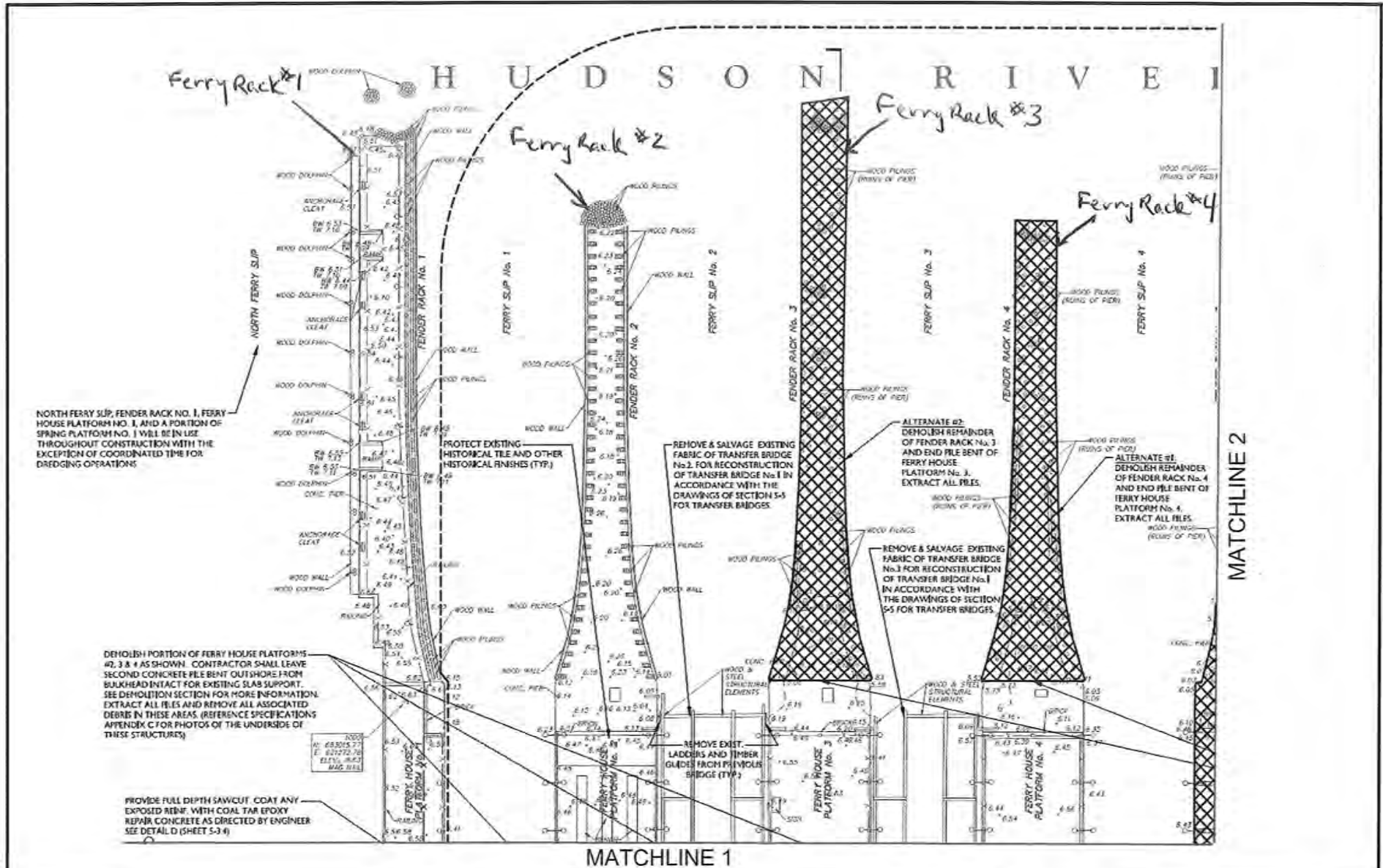

Figure 3 of 20

MASER
CONSULTING P.A.

Customer Loyalty through Client Satisfaction
www.maserconsulting.com

Engineers ■ Planners ■ Surveyors
Landscape Architects ■ Environmental Scientists

State of N.J. Cert. of Authorization: 24GA2798500

Office Locations:

- Albany, NY
- Red Bank, NJ
- Clinton, NJ
- Hamilton, NJ
- Marmora, NJ
- Mt. Arlington, NJ
- Mt. Laurel, NJ
- Sterling, VA
- Norfolk, VA
- Albuquerque, NM
- Albany, NY
- Chestnut Ridge, NY
- Newburgh, NY
- Hawthorne, NY
- Lehigh Valley, PA
- Exton, PA
- Philadelphia, PA
- Tampa, FL
- Miami, FL
- Columbia, MD

Copyright © 2016 Maser Consulting P.A. All Rights Reserved. This drawing and its contents are confidential and intended for use only by the party for whom the services were contracted and to whom it is directed. This drawing may not be copied, revised, displayed, distributed or used again for any other purpose without the express written consent of Maser Consulting P.A.

REV	DATE	DRAWN BY	DESCRIPTION

LIBERTY STATE PARK
FERRY SLIP
RECONSTRUCTION

ARMY CORPS OF
ENGINEERS PERMIT
PLANS ONLY

JERSEY CITY
HUDSON COUNTY
STATE OF NEW JERSEY

811
PROTECT YOURSELF
ALL STATES REQUIRE NOTIFICATION
OF EXCAVATORS, DIGGERS, OR
ANY TRASH PREPARING TO
DISTURB THE EARTH'S SURFACE
ANYWHERE IN ANY STATE

Know what's below.
Call before you dig.
FOR STATE SPECIFIC DIRECT PHONE NUMBERS
VISIT: WWW.CALL811.COM

RED BANK OFFICE
Corporate Headquarters
338 Newman Springs Road
Suite 203
Red Bank, NJ 07701

Phone: 732.383.1550
Fax: 732.383.1984

ARMY CORPS OF ENGINEERS PERMIT
PLANS

SCALE	DATE	DRAWN BY	CHECKED BY
AS SHOWN	06/08/16	AEO	RCM
PROJECT NUMBER:	DRAWING NAME:		
1400185A	MASER - TITLE LOCK SMALL		
SHEET NUMBER:			
C1.2-4			

MATCHLINE 1

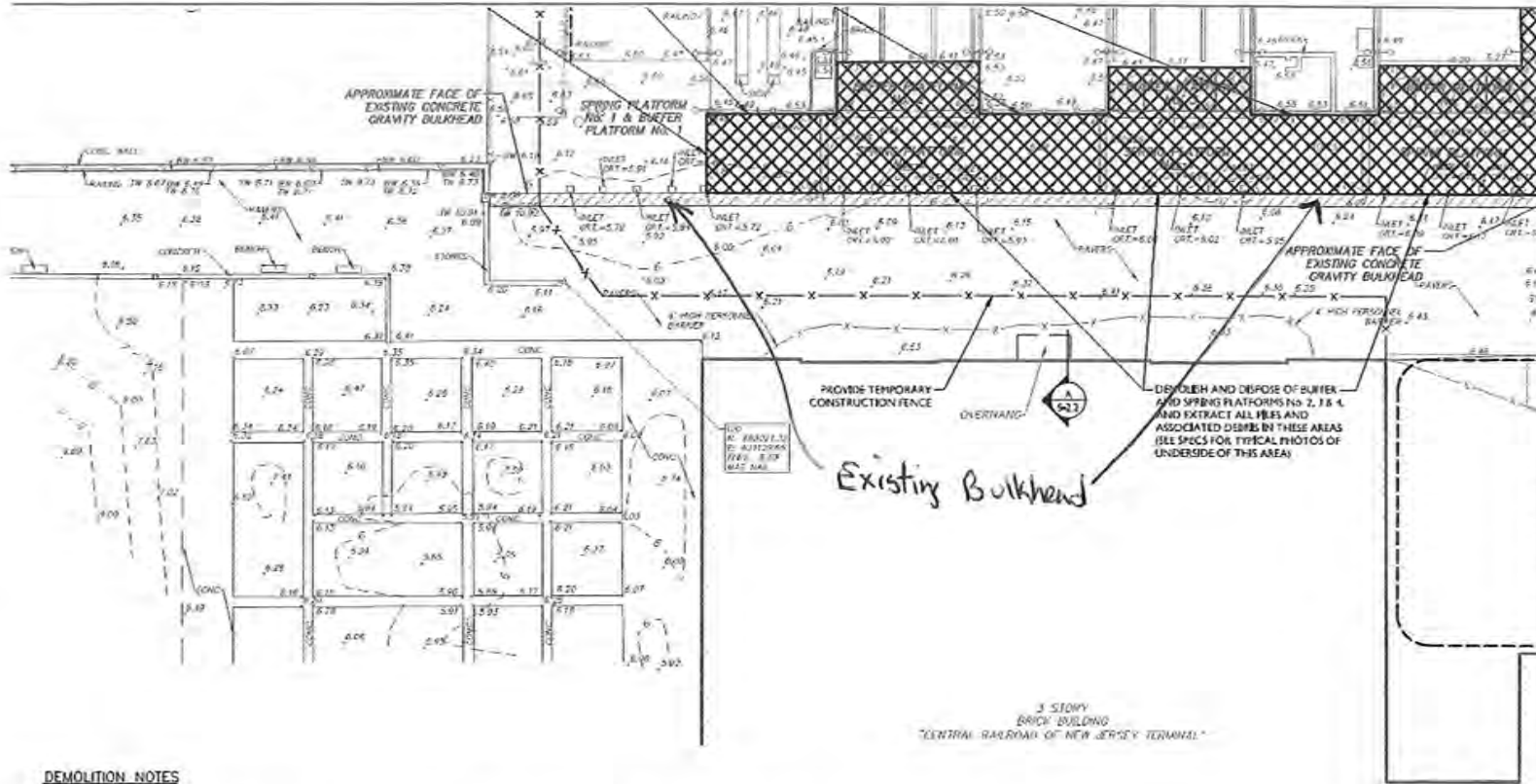

MATCHLINE 4

DEMOLITION NOTES

1. SUBMIT A DEMOLITION PLAN FOR REVIEW AND APPROVAL PRIOR TO THE START OF DEMOLITION. THE DEMOLITION PLAN SHALL INCLUDE EQUIPMENT AND PROCEDURES FOR DEMOLITION; AND METHODS FOR CONTAINMENT AND DISPOSAL OF DEBRIS. ALL DEBRIS SHALL BE DISPOSED OF OFF-SITE.
2. SHIELDING OR OTHER METHODS SHALL BE PROVIDED TO PREVENT DEBRIS FROM ENTERING THE WATERWAY. ANY DEBRIS ENTERING THE WATERWAY SHALL BE IMMEDIATELY REMOVED.
3. ALL INTERFACES BETWEEN THE "TO BE REMOVED" AND THE "TO REMAIN" ITEMS SHALL BE SAWCUT ALONG THE LIMITS OF REMOVAL PRIOR TO THE START OF DEMOLITION.
4. USE EXTREME CAUTION TO PREVENT DAMAGE TO EXISTING STRUCTURES DESIGNATED TO REMAIN. IN THE EVENT THAT THERE IS DAMAGE TO THE STRUCTURES DESIGNATED TO REMAIN, SUBMIT A REPAIR PLAN FOR REVIEW AND APPROVAL. REPAIR DAMAGED AREAS PER THE APPROVED PLAN.
5. DISPOSE OF OR RECYCLE REMOVED DEBRIS AND MATERIALS ACCORDING TO SOLID WASTE MANAGEMENT ACT (N.J.S.A. 13:1E-1) AND N.J.A.C. 7:26 ET SEQ. AND ACCORDING TO THE SOLID WASTE MANAGEMENT PLAN DEVELOPED BY THE SOLID WASTE MANAGEMENT DISTRICT OF ORIGIN.

Figure 4 of 20



Customer Loyalty through Client Satisfaction
www.maserconsulting.com

Engineers • Planners • Surveyors
Landscape Architects • Environmental Scientists

State of N.J. Cert. of Authorization: 24GA27986500

Office Locations:

- Albany, NY
- Red Bank, NJ
- Clinton, NJ
- Hamilton, NJ
- Marmor, NJ
- Mt. Arlington, NJ
- Mt. Laurel, NJ
- Sterling, VA
- Norfolk, VA
- Albuquerque, NM
- Albany, NY
- Chestnut Ridge, NY
- Newburgh, NY
- Hawthorne, NY
- Lehigh Valley, PA
- Exton, PA
- Philadelphia, PA
- Tampa, FL
- Miami, FL
- Columbia, MD

Copyright © 2016 Maser Consulting P.A. All Rights Reserved. This drawing and all its information are the property of Maser Consulting P.A. and shall remain the property of Maser Consulting P.A. No part of this drawing may be reproduced, stored in a retrieval system, or transmitted in any form or by any means, electronic, mechanical, photocopying, recording, or by any information storage and retrieval system, without the prior written permission of Maser Consulting P.A.

REV	DATE	DRAWN BY	DESCRIPTION

LIBERTY STATE PARK
FERRY SLIP
RECONSTRUCTION

ARMY CORPS OF
ENGINEERS PERMIT
PLANS ONLY

JERSEY CITY
HUDSON COUNTY
STATE OF NEW JERSEY

811 PROTECT YOURSELF
ALL STATES REQUIRE NOTIFICATION
OF EXCAVATORS, DESIGNERS, OR
ANY PERSON PREPARING TO
DISTURB THE EARTH'S SURFACE
ANYWHERE IN ANY STATE

Know what's below.
Call before you dig.
FOR STATE SPECIFIC DIRECT PHONE NUMBERS
VISIT: WWW.CALL811.COM

RED BANK OFFICE
Corporate Headquarters
331 Newman Springs Road
Suite 207
Red Bank, NJ 07701

Phone: 732.383.1850
Fax: 732.383.1924

ARMY CORPS OF ENGINEERS PERMIT
PLANS

SCALE	DATE	DRAWN BY	CHECKED BY
AS SHOWN	05/09/16	AED	RCM

PROJECT NUMBER: 14001855A
DRAWING NAME: MASER - TITLEBLOCK SHALL

SHEET NUMBER: C1.2-3

MATCHLINE 3

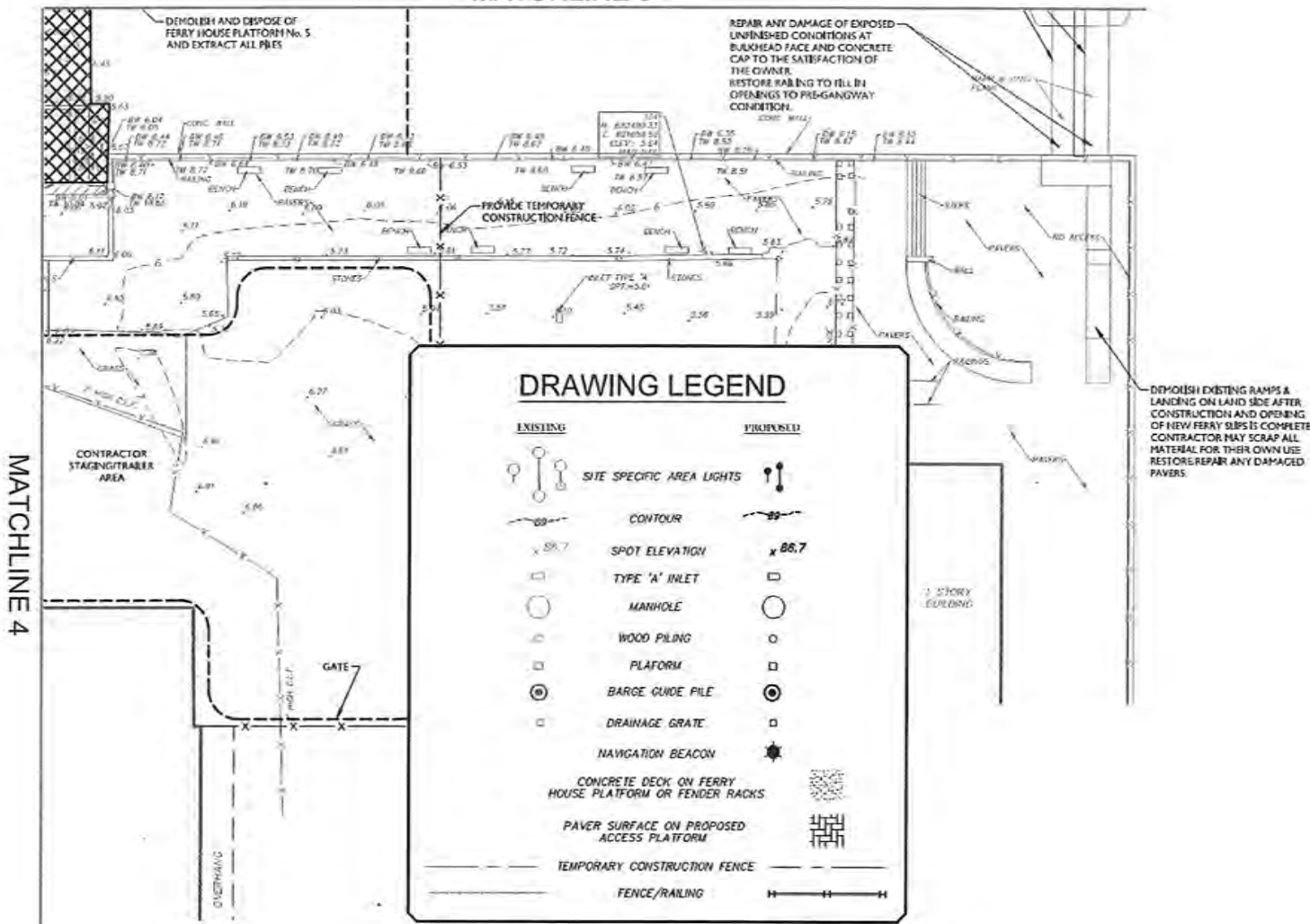

MATCHLINE 4

Figure 6 of 20



Customer Loyalty through Client Satisfaction
www.maserconsulting.com

Engineers • Planners • Surveyors
Landscape Architects • Environmental Scientists
State of N.J. Cert. of Authorization: 24GA27986500

- Office Locations:
- Albany, NY
 - Red Bank, NJ
 - Clinton, NJ
 - Chestnut Ridge, NY
 - Hamilton, NJ
 - Hawthorne, NY
 - Lehigh Valley, PA
 - Exton, PA
 - Philadelphia, PA
 - Tampa, FL
 - Miami, FL
 - Columbia, MD
 - Sterling, VA
 - Norfolk, VA
 - Albuquerque, NM
 - Mc. Laurel, NJ
 - Mc. Arlington, NJ
 - Morris, NJ
 - Marmora, NJ

Copyright © 2016 Maser Consulting P.A. All Rights Reserved. This drawing and all its information contained herein is unclassified and not for sale. The drawing may not be reproduced, modified, distributed or used for any other purpose without the express written consent of Maser Consulting P.A.

REV	DATE	DRAWN BY	DESCRIPTION

LIBERTY STATE PARK
FERRY SLIP
RECONSTRUCTION

ARMY CORPS OF
ENGINEERS PERMIT
PLANS ONLY

JERSEY CITY
HUDSON COUNTY
STATE OF NEW JERSEY

811
PROTECT YOURSELF
ALL STATES REQUIRE NOTIFICATION
OF EXCAVATORS, DESIGNERS, OR
ANY PERSON PREPARING TO
DISTURB THE EARTH'S SURFACE
ANYWHERE IN ANY STATE

Know what's below.
Call before you dig.
FOR STATE SPECIFIC DIRECT PHONE NUMBERS
VISIT: WWW.CALL811.COM

MASER
RED BANK OFFICE
Corporate Headquarters
331 Newman Springs Road
Suite 203
Red Bank, NJ 07701
Phone: 732.383.1950
Fax: 732.383.1954

ARMY CORPS OF ENGINEERS PERMIT PLANS			
SCALE	DATE	DRAWN BY	CHECKED BY
AS SHOWN	06/08/16	AEO	RCM
PROJECT NUMBER:	DRAWING NAME:		
14001855A	MASER - TITLEBLOCK SMALL		
SHEET TITLE			
SHEET NUMBER:			
C1.2-4			

425 feet to approximate Federal Channel limit

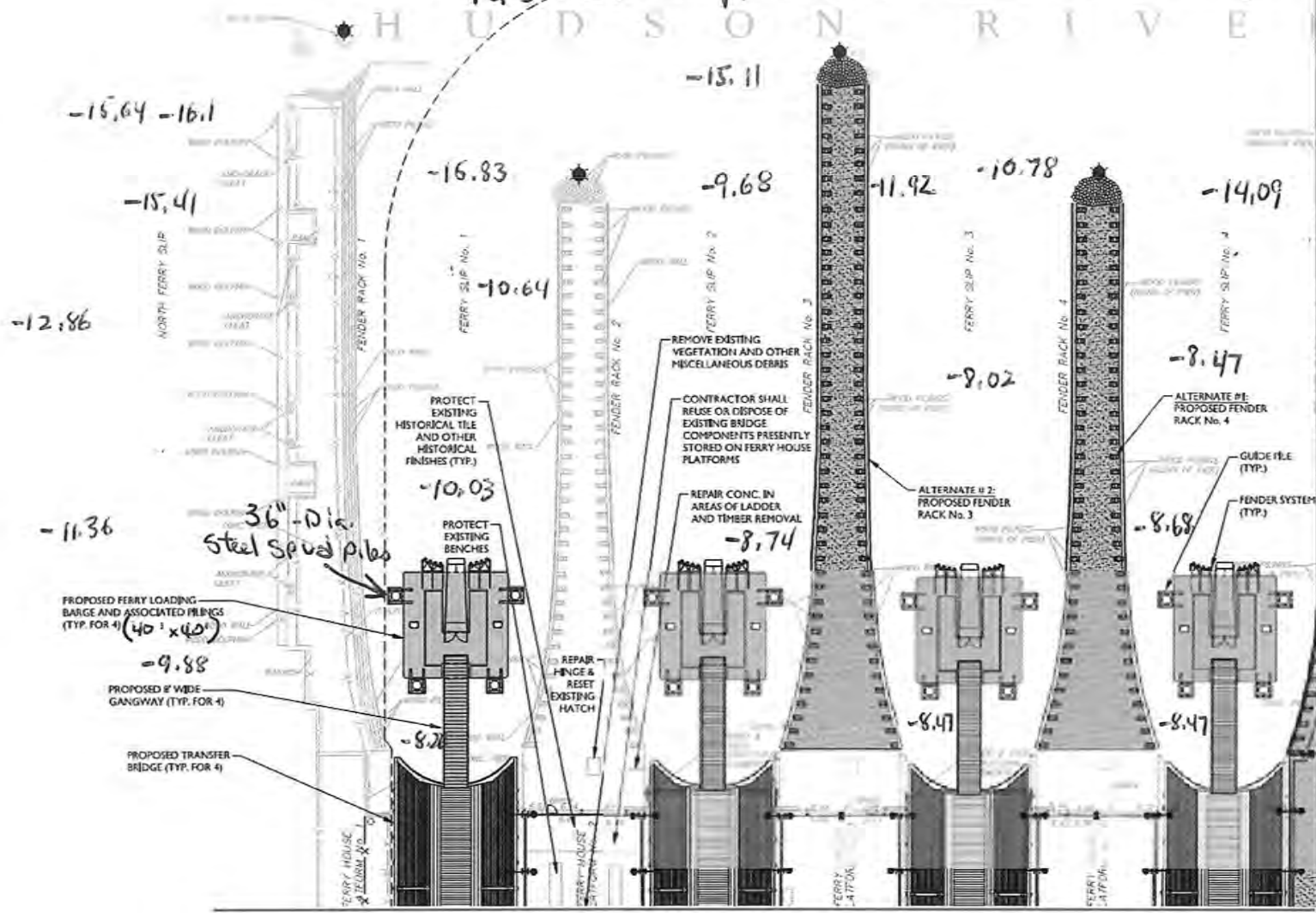

MATCHLINE 1

MATCHLINE 2

Figure 7 of 20



Customer Loyalty through Client Satisfaction
www.maserconsulting.com
 Engineers ■ Planners ■ Surveyors
 Landscape Architects ■ Environmental Scientists
 State of N.J. Cert. of Authorization: 24GA27986500
 Copyright © 2016 Maser Consulting P.A. All Rights Reserved. This drawing and all information contained herein is authorized for use only by the party for whom the services were contracted or to whom the services were rendered. This drawing may not be copied, revised, distributed or relied upon for any other purpose without the express written consent of Maser Consulting P.A.

Office Locations:
 ■ Red Bank, NJ
 ■ Clinton, NJ
 ■ Hamilton, NJ
 ■ Marmora, NJ
 ■ Mc. Arlington, NJ
 ■ Mc. Laurel, NJ
 ■ Sterling, VA
 ■ Norfolk, VA
 ■ Albuquerque, NM
 ■ Albany, NY
 ■ Chestnut Ridge, NY
 ■ Newburgh, NY
 ■ Hawthorne, NY
 ■ Lehigh Valley, PA
 ■ Exton, PA
 ■ Philadelphia, PA
 ■ Tampa, FL
 ■ Miami, FL
 ■ Columbia, MD

REV	DATE	DRAWN BY	DESCRIPTION

LIBERTY STATE PARK
 FERRY SLIP
 RECONSTRUCTION

ARMY CORPS OF
 ENGINEERS PERMIT
 PLANS ONLY

JERSEY CITY
 HUDSON COUNTY
 STATE OF NEW JERSEY

811 PROTECT YOURSELF
 ALL STATES REQUIRE NOTIFICATION
 OF OCCUPATIONAL DESIGNERS OR
 ANY PERSON PREPARED TO
 DISTURB THE EARTH'S SURFACE
 ANYWHERE IN ANY STATE

Know what's below.
 Call before you dig.
 FOR STATE SPECIFIC DIRECT PHONE NUMBERS
 VISIT: WWW.CALL811.COM

RED BANK OFFICE
 Corporate Headquarters
 331 Newman Springs Road
 Suite 203
 Red Bank, NJ 07701
 Phone: 732.383.8550
 Fax: 732.383.1984

ARMY CORPS OF ENGINEERS PERMIT PLANS			
SCALE	DATE	DRAWN BY	CHECKED BY
AS SHOWN	05/08/16	AEO	RCM
PROJECT NUMBER:	DRAWING NAME:		
14001865A	MASER - TITLEBLOCK SMALL		
SHEET TITLE:			
SHEET NUMBER:			
C1.3-1			

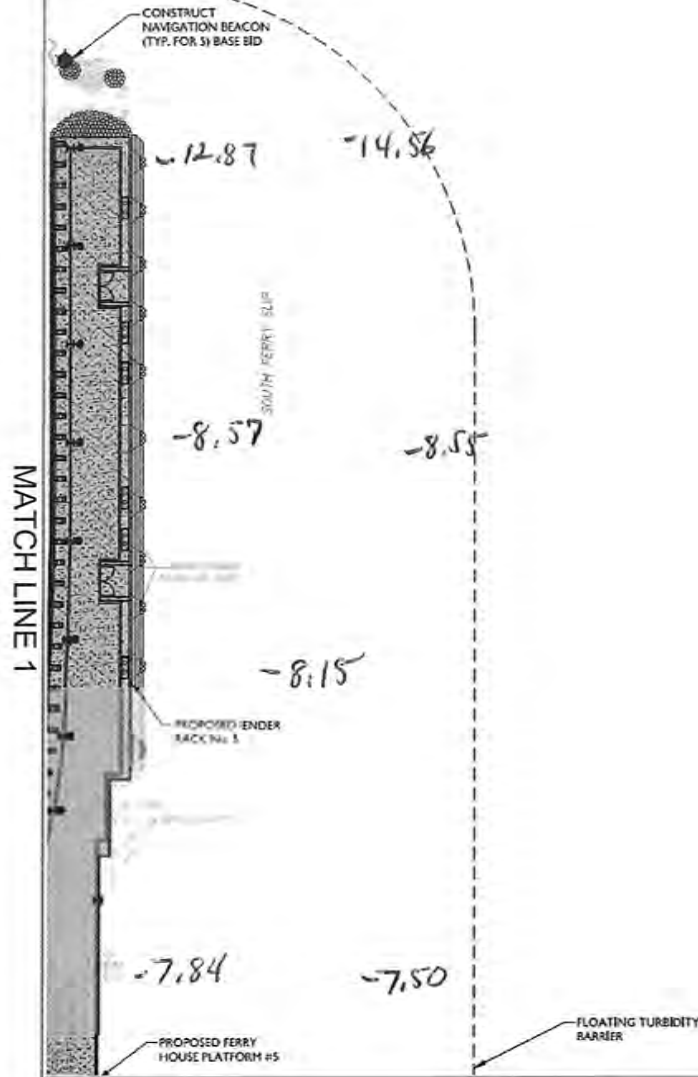

Figure 8 of 20



Customer Loyalty through Client Satisfaction
www.maserconsulting.com

Engineers ■ Planners ■ Surveyors
 Landscape Architects ■ Environmental Scientists

State of N.J. Cert. of Authorization: 24GA27986500

Copyright © 2016 Maser Consulting P.A. All Rights Reserved. This drawing and all its information cannot be reproduced or used in any way without the express written consent of Maser Consulting P.A.

Office Locations:

- Red Bank, NJ
- Clinton, NJ
- Hamilton, NJ
- Marmora, NJ
- Mt. Arlington, NJ
- Mt. Laurel, NJ
- Sterling, VA
- Norfolk, VA
- Albuquerque, NM
- Albany, NY
- Chestnut Ridge, NY
- Newburgh, NY
- Haworth, NY
- Lehigh Valley, PA
- Exton, PA
- Philadelphia, PA
- Tampa, FL
- Miami, FL
- Columbia, MD

REV	DATE	DRAWN BY	DESCRIPTION

LIBERTY STATE PARK
 FERRY SLIP
 RECONSTRUCTION

ARMY CORPS OF
 ENGINEERS PERMIT
 PLANS ONLY

JERSEY CITY
 HUDSON COUNTY
 STATE OF NEW JERSEY

811 PROTECT YOURSELF
 ALL STATES REQUIRE NOTIFICATION
 OF EXCAVATIONS, DESIGNERS, OR
 ANY PERSON PREPARING TO
 DISTURB THE EARTH'S SURFACE
 ANYWHERE IN ANY STATE

Know what's below.
 Call before you dig.
 FOR STATE SPECIFIC DIRECT PHONE NUMBERS
 VISIT: WWW.CALL811.COM

RED BANK OFFICE
 Corporate Headquarters
 331 Newman Springs Road
 Suite 203
 Red Bank, NJ 07701
 Phone: 732.383.1950
 Fax: 732.383.1984

ARMY CORPS OF ENGINEERS PERMIT PLANS			
SCALE AS SHOWN	DATE 06/08/16	DRAWN BY AEO	CHECKED BY RCM
PROJECT NUMBER 14001865A	DRAWING NAME MASER - TITLEBLOCK SMALL		
SHEET TITLE			
SHEET NUMBER C1.3-2			

MATCHLINE 1

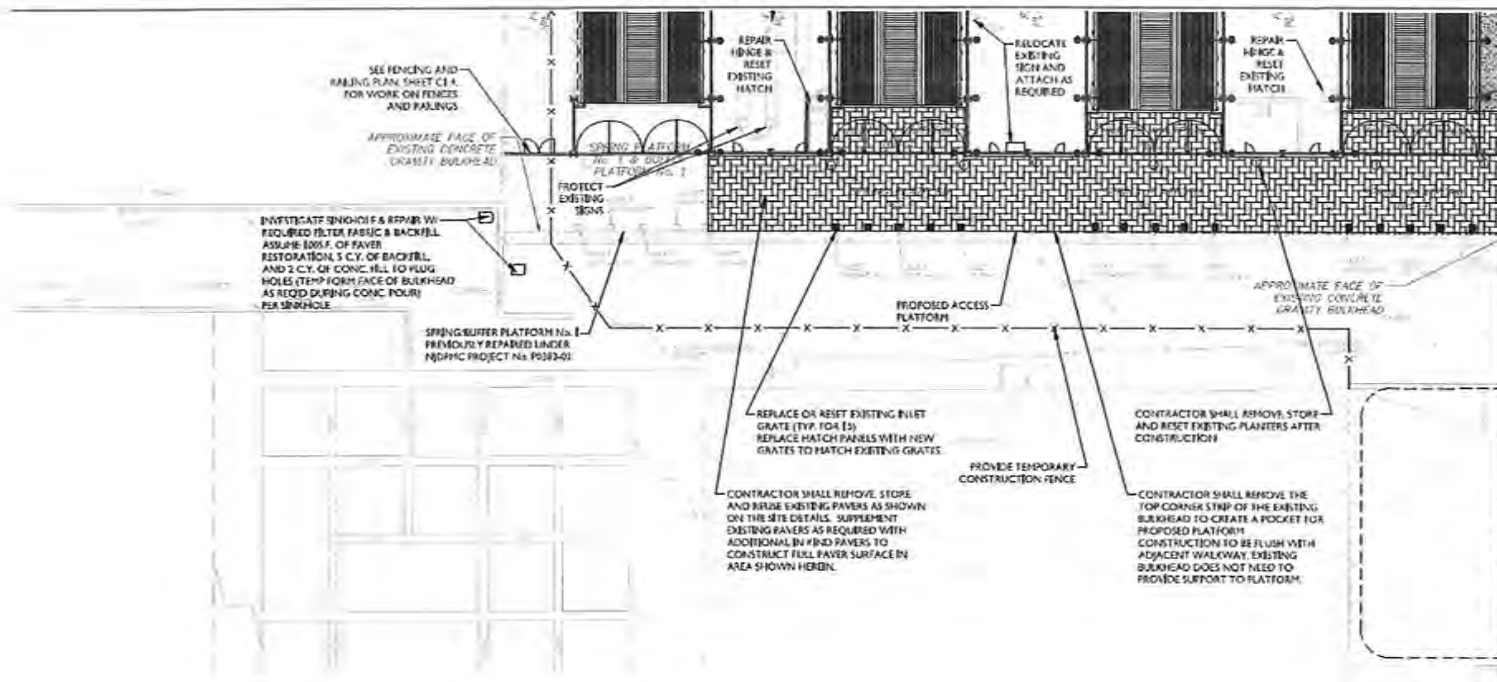

SCOPE OF WORK

- BASE BID:** ALL WORK SHOWN THROUGHOUT PLAN SET IS TO BE COMPLETED AS PART OF THE BASE BID OF THIS PROJECT UNLESS NOTED OTHERWISE AS PERTAINING TO ALTERNATE #1 OR ALTERNATE #2.
- ALTERNATE #1:** ALL WORK ASSOCIATED WITH FENDER RACK No. 4 SHALL BE INCLUDED IN ALTERNATE #1. THIS WORK HAS BEEN LABELED AS SUCH.
- ALTERNATE #2:** ALL WORK ASSOCIATED WITH FENDER RACK No. 3 SHALL BE INCLUDED IN ALTERNATE #2. THIS WORK HAS BEEN LABELED AS SUCH.

HISTORICAL INFORMATIONAL SIGNS

1. ALL SIGNS SPECIFIED TO BE PROTECTED SHALL BE REMOVED, STORED AND REINSTALLED USING NEW STAINLESS STEEL HARDWARE.
2. ALL SIGNS SPECIFIED TO BE RELOCATED SHALL BE REMOVED, STORED AND REINSTALLED USING NEW STAINLESS STEEL HARDWARE AND BASEPLATE.

HATCHES

1. ALL HATCH RESTORATION
2. CONTR PRECO RESTO AND SPECIF

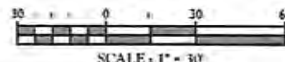

Figure 19 of 20

MASER CONSULTING P.A.

Customer Loyalty through Client Satisfaction
www.maserconsulting.com

Engineers ■ Planners ■ Surveyors
Landscape Architects ■ Environmental Scientists

State of N.J. Cert. of Authorization: 24GA27966500

Office Locations:

■ Albany, NY	■ Red Bank, NJ	■ Albany, NY
■ Chestnut Ridge, NY	■ Clinton, NJ	■ Newburgh, NY
■ Hamilton, NJ	■ Hawthorne, NY	■ Marmora, NJ
■ Lehigh Valley, PA	■ Mt. Arlington, NJ	■ Exton, PA
■ Philadelphia, PA	■ Mt. Laurel, NJ	■ Philadelphia, PA
■ Sterling, VA	■ Norfolk, VA	■ Tampa, FL
■ Miami, FL	■ Albuquerque, NM	■ Columbia, MD

Copyright © 2016 Maser Consulting P.A. All Rights Reserved. This drawing and all information contained herein is authorized for use only by the party for whom the services were rendered or its successors in title. The drawing may not be copied, reused, distributed, or used in any way without the express written permission of Maser Consulting P.A.

REV	DATE	DRAWN BY	DESCRIPTION

LIBERTY STATE PARK
FERRY SLIP
RECONSTRUCTION

ARMY CORPS OF
ENGINEERS PERMIT
PLANS ONLY

JERSEY CITY
HUDSON COUNTY
STATE OF NEW JERSEY

811 PROTECT YOURSELF
ALL STATES REQUIRE NOTIFICATION OF EXCAVATORS, DESIGNERS, OR ANY PERSON PREPARING TO DISTURB THE EARTH'S SURFACE ANYWHERE IN ANY STATE

Know what's below.
Call before you dig.

FOR STATE SPECIFIC DIRECT PHONE NUMBERS VISIT: WWW.CALL811.COM

RED BANK OFFICE
Corporate Headquarters
333 Newman Springs Road
Suite 207
Red Bank, NJ 07701
Phone: 732.383.1550
Fax: 732.383.1984

ARMY CORPS OF ENGINEERS PERMIT PLANS

SCALE	DATE	DRAWN BY	CHECKED BY
AS SHOWN	06/08/16	AEO	RCH

PROJECT NUMBER: 14001865A
DRAWING NAME: MASER - TITLEBLOCK SMALL

SHEET NUMBER: C1.3-3

MATCH LINE 3

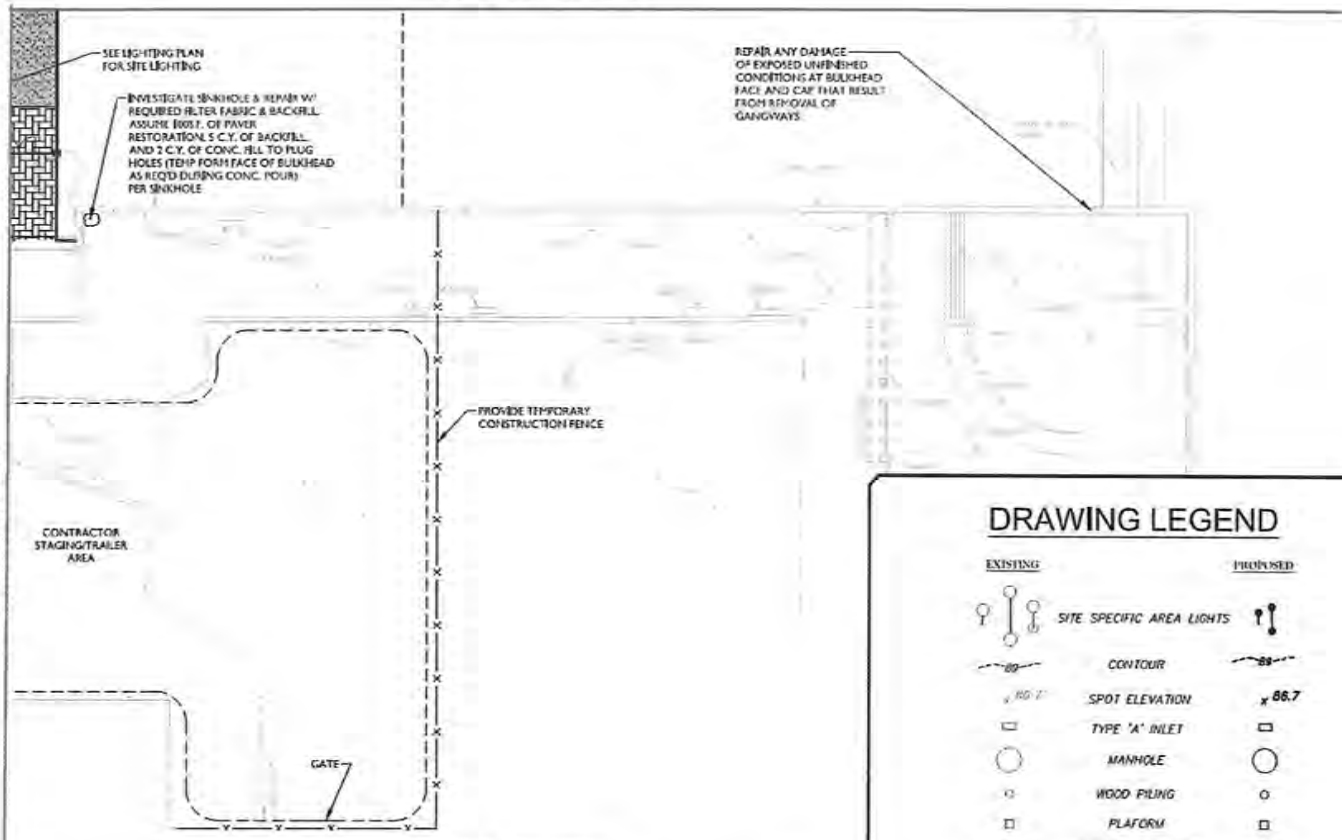

RACKS SPECIFIED TO BE RESET SHALL BE REPAIRED TO RE THEIR ORIGINAL FUNCTIONALITY

CONTRACTOR SHALL REMOVE ALL WEEDS, TRASH AND LANEWAYS NON-HISTORIC DEBRIS WITHIN TEMPORARY CONSTRUCTION FENCE, INCLUDING THAT FOUND ON EXISTING FERRY HOUSE PLATFORMS.

CONTRACTOR SHALL RESTORE STAGING AREA TO ITS ORIGINAL CONSTRUCTION CONDITION. GRASSED AREAS SHALL BE RESEED WITH TOPSOIL, 4" THICK, FERTILIZER, SEEDING TRAW MULCH AS DESCRIBED IN THE PROJECT SPECIFICATIONS

- MARINE NAVIGATION BEACON**
1. LIGHT FIXTURE AT OUTER END OF FENDER RACKS SHALL BE A SOLAR-POWERED NAVIGATION FIXTURE, SUITABLE FOR MARINE EXPOSURES.
 2. FIXTURE SHALL BE A RED FLASHING BEACON, WITH FLASH INTERVAL OF 2.5 SECONDS, PER US COAST GUARD, NEW YORK AREA OFFICE. (718-354-4354).
 3. SELECTION OF BEACON, APPLICATION FOR BEACON INSTALLATION PERMIT, AND MAINTENANCE OF BEACON SHALL BE COORDINATED WITH THE US COAST GUARD AND THE OFFICE OF THE "NEW JERSEY AIDS TO NAVIGATION", PRIOR TO INSTALLATION.
 4. SEE SPECIFICATIONS FOR ADDITIONAL INFORMATION.

DRAWING LEGEND

EXISTING	PROPOSED

Figure 10 of 20

MASER CONSULTING P.A.

Customer Loyalty through Client Satisfaction
www.maserconsulting.com

Engineers • Planners • Surveyors
Landscape Architects • Environmental Scientists

State of N.J. Cert. of Authorization: 24GA27986500

Office Locations:

■ Red Bank, NJ	■ Albany, NY
■ Clinton, NJ	■ Chestnut Ridge, NY
■ Hamilton, NJ	■ Newburgh, NY
■ Hammora, NJ	■ Hawthorne, NY
■ Mt. Arlington, NJ	■ Lehigh Valley, PA
■ Mt. Laurel, NJ	■ Exton, PA
■ Sterling, VA	■ Philadelphia, PA
■ Norfolk, VA	■ Tampa, FL
■ Albuquerque, NM	■ Miami, FL
	■ Columbia, MD

Copyright © 2016 Maser Consulting P.A. All Rights Reserved. This drawing and all its contents are confidential and shall remain the property of Maser Consulting P.A. No part of this drawing may be reproduced, stored in a retrieval system, or transmitted in any form or by any means, electronic, mechanical, photocopying, recording, or by any information storage and retrieval system, without the express written consent of Maser Consulting P.A.

REV	DATE	DRAWN BY	DESCRIPTION
-	-	-	-
-	-	-	-
-	-	-	-
-	-	-	-
-	-	-	-
-	-	-	-

LIBERTY STATE PARK
FERRY SLIP
RECONSTRUCTION

ARMY CORPS OF
ENGINEERS PERMIT
PLANS ONLY

JERSEY CITY
HUDSON COUNTY
STATE OF NEW JERSEY

811

PROTECT YOURSELF
ALL STATES REQUIRE NOTIFICATION OF EXCAVATIONS, DISCOVERIES, OR ANY PUNCH PREPARED TO DISTURB THE EARTH'S SURFACE ANYWHERE IN ANY STATE.

Know what's below.
Call before you dig.
FOR STATE SPECIFIC DIRECT PHONE NUMBERS VISIT: WWW.CALL811.COM

RED BANK OFFICE
Corporate Headquarters
331 Newman Springs Road
Suite 203
Red Bank, NJ 07701
Phone: 732.383.1950
Fax: 732.383.1984

ARMY CORPS OF ENGINEERS PERMIT PLANS

SCALE	DATE	DRAWN BY	CHECKED BY
AS SHOWN	06/08/16	AEO	RCM
PROJECT NUMBER:	DRAWING NAME:		
14001865A	MASER - TITLE BLOCK SMALL		
SHEET TITLE:			
SHEET NUMBER:			
C1.3-4			

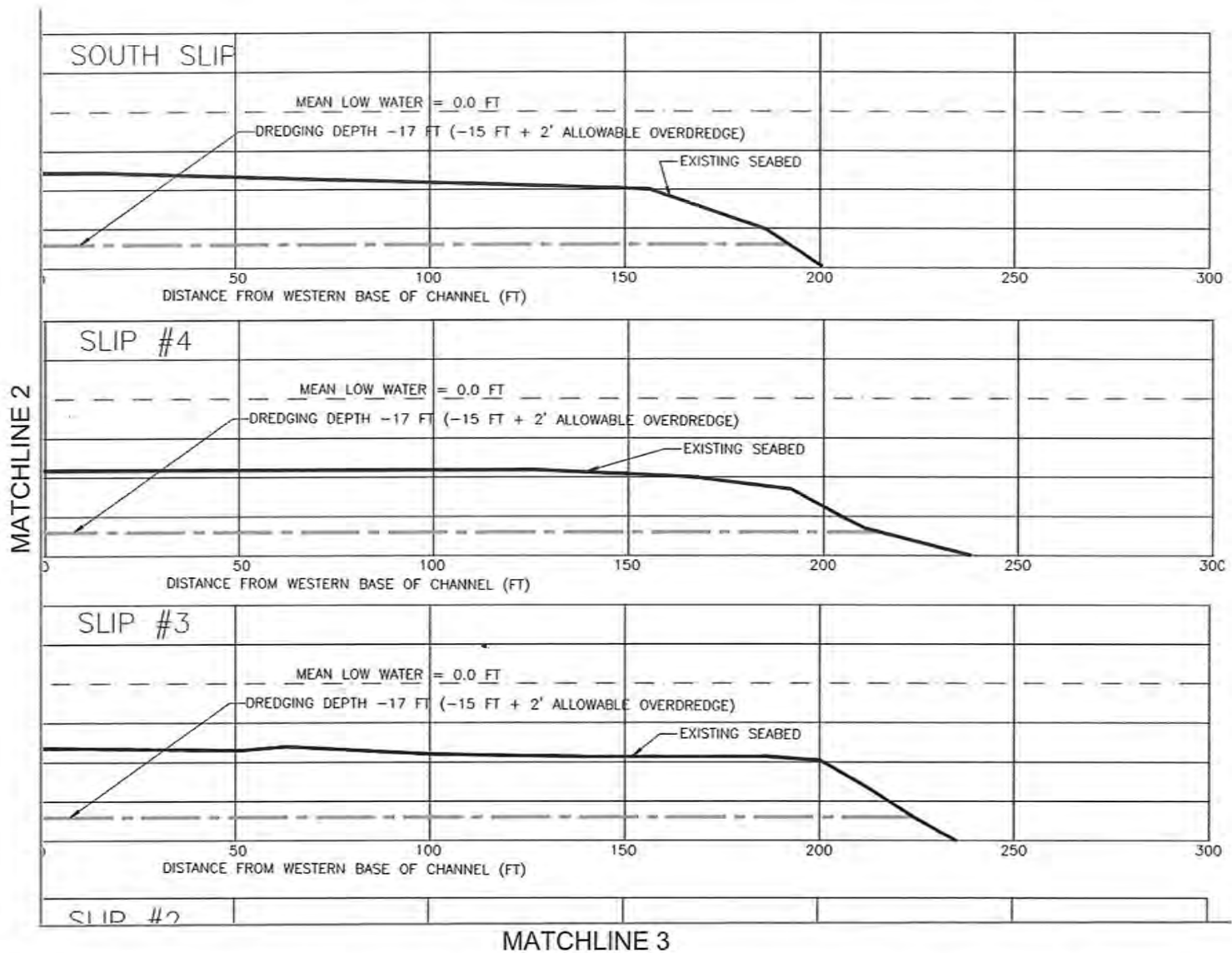

Figure 12 of 20



Customer Loyalty through Client Satisfaction
www.maserconsulting.com

Engineers ■ Planners ■ Surveyors
Landscape Architects ■ Environmental Scientists

State of N.J. Cert. of Authorization: 24GA27986500

Office Locations:

- Red Bank, NJ
- Clinton, NJ
- Hamilton, NJ
- Marmora, NJ
- Mt. Arlington, NJ
- Mt. Laurel, NJ
- Sterling, VA
- Norfolk, VA
- Albuquerque, NM
- Albany, NY
- Chestnut Ridge, NY
- Newburgh, NY
- Haworth, NY
- Lehigh Valley, PA
- Exton, PA
- Philadelphia, PA
- Tampa, FL
- Miami, FL
- Columbia, MD

Copyright © 2016 Maser Consulting P.A. All Rights Reserved. This drawing and all information contained herein is authorized for use only by the party for whom the services were rendered or to whom it is loaned. This drawing may not be copied, reprinted, distributed or used again for any other project without the express written consent of Maser Consulting P.A.

REV	DATE	DRAWN BY	DESCRIPTION

LIBERTY STATE PARK
FERRY SLIP
RECONSTRUCTION

ARMY CORPS OF
ENGINEERS PERMIT
PLANS ONLY

JERSEY CITY
HUDSON COUNTY
STATE OF NEW JERSEY

811
Know what's below.
Call before you dig.
FOR STATE SPECIFIC DIRECT PHONE NUMBERS
VISIT: WWW.CALL811.COM

PROTECT YOURSELF
ALL STATES REQUIRE NOTIFICATION
OF EXCAVATORS, DESIGNERS, OR
ANY PERSON PREPARING TO
DISTURB THE EARTH'S SURFACE
ANYWHERE IN ANY STATE

MASER
RED BANK OFFICE
Corporate Headquarters
331 Newman Springs Road
Suite 203
Red Bank, NJ 07701
Phone: 732.383.1550
Fax: 732.383.1984

ARMY CORPS OF ENGINEERS PERMIT PLANS			
SCALE	DATE	DRAWN BY	CHECKED BY
AS SHOWN	06/08/16	AEO	RCM
PROJECT NUMBER	DRAWING NAME		
14001865A	MASER - TITLEBLOCK SMALL		
SHEET TITLE			
SHEET NUMBER:			C1.6-2

MATCHLINE 1

 AREA OF DREDGING (-17 FT)

- * DREDGING SIDE SLOPES NOT SHOWN FOR CLARITY
- * DISTANCE OF PROPOSED CONSTRUCTION LIMIT TO FEDERAL CHANNEL = 425 FT±

DREDGING ELEVATION (BELOW MLW)	DREDGING VOLUME (CY)						
	SOUTH SLIP	SLIP 4	SLIP 3	SLIP 2	SLIP 1	NORTH SLIP	TOTAL
AT -15'	3286	2766	2897	2529	2013	1173	14664
+2' ALLOWABLE OVERDREDGE	1124	987	950	978	972	898	5909
TOTAL -17'	4410	3753	3847	3507	2985	2071	20573
	DREDGING AREAS (SF)						
	SOUTH SLIP	SLIP 4	SLIP 3	SLIP 2	SLIP 1	NORTH SLIP	TOTAL
	15842	13205	13035	13705	14128	12536	82451

NOTES

- HYDROGRAPHIC SURVEY SHOWN HEREON BEING WITHIN A PORTION OF TAX LOT 12, 13, 14 AND 15 BLOCK 15904, SAID TAX LOTS AS SHOWN ON THE CURRENT TAX MAPS FOR THE CITY OF JERSEY CITY, HUDSON COUNTY, NEW JERSEY, TAX SHEET No. 159..
- HORIZONTAL DATUM—MAD 1983, BASED UPON GPS OBSERVATIONS PERFORMED BY RIOUX ENGINEERING L.L.C. ON MARCH 29, 2015 REFERRING TO LEICA SMARTNET CONTINUOUSLY OPERATING REFERENCE STATION (CORS) NEWARK.
- VERTICAL DATUM—MEAN LOW WATER, BASED UPON GPS OBSERVATIONS PERFORMED BY RIOUX ENGINEERING L.L.C. ON MARCH 29, 2015 REFERRING TO LEICA SMARTNET CONTINUOUSLY OPERATING REFERENCE STATION (CORS) NEWARK.
- TIDAL ELEVATION REFERENCE TO NATIONAL GEODETIC TIDAL BENCH MARK: "851-8750 TIDAL 7" (POINT IDENTIFICATION NUMBER AB6736) ELEVATION=11.88 FEET, (NAVD 1988).
- HYDROGRAPHIC DATA SHOWN HEREON IS BASED ON FIELD OBSERVATIONS AS PERFORMED BY RIOUX ENGINEERING L.L.C., ON MARCH 29, 2015.
- SPOT ELEVATION LINES AND CONTOUR LINES SHOWN ON THE HYDROGRAPHIC SURVEY ORIGINATED FROM A LARGER POINT DATABASE.
- NOT ALL UPLAND IMPROVEMENTS SHOWN.

TIDAL ELEVATION
(U.S. SURVEY FEET MEAN LOW WATER)

	MLW	NAVD88
MEAN HIGH HIGH WATER	4.85'	2.28'
MEAN HIGH WATER	4.53'	1.96'
NAVD 1988	2.57'	0.00'
MEAN TIDE LEVEL	2.27'	-0.30'
MEAN LOW WATER	0.00'	-2.57'
MEAN LOWER LOW WATER	-0.20'	-2.77'

TIDAL ELEVATION SHOWN BASED ON:

TIDAL DATA AND BENCHMARK: ELEVATION SHEET "851-8750" THE BATTERY, NY (TIDAL EPOCH 1983 - 2001)

LEGEND

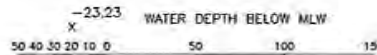

GRAPHIC SCALE
1 inch=50 feet

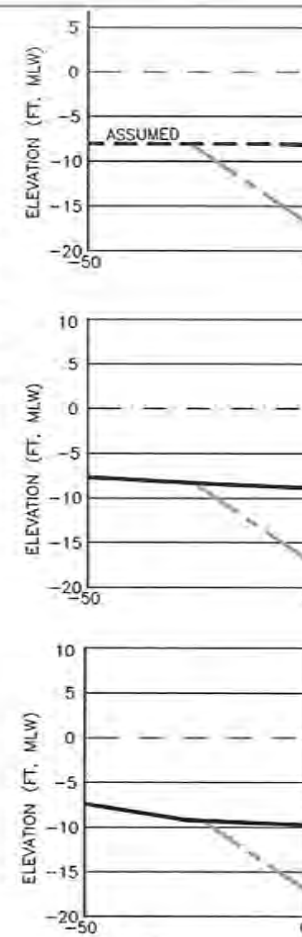

MATCHLINE 4

Figure 13 of 20



Customer Loyalty through Client Satisfaction
www.maserconsulting.com

Office Locations:

■ Red Bank, NJ	■ Albany, NY
■ Clinton, NJ	■ Chestnut Ridge, NY
■ Hamilton, NJ	■ Newburgh, NY
■ Marmora, NJ	■ Hawthorne, NY
■ Mt. Arlington, NJ	■ Lehigh Valley, PA
■ Mt. Laurel, NJ	■ Exton, PA
■ Sterling, VA	■ Philadelphia, PA
■ Norfolk, VA	■ Tampa, FL
■ Albuquerque, NM	■ Miami, FL
	■ Columbia, MD

State of N.J. Cert. of Authorization: 24GA37986500

Copyright © 2016 Maser Consulting P.A. All Rights Reserved. This drawing is the intellectual property of Maser Consulting P.A. and is not to be reproduced, stored in a retrieval system, or transmitted in any form or by any means, electronic, mechanical, photocopying, recording, or by any information storage and retrieval system, without the prior written permission of Maser Consulting P.A.

REV	DATE	DRAWN BY	DESCRIPTION
-	-	-	-
-	-	-	-
-	-	-	-
-	-	-	-
-	-	-	-
-	-	-	-

LIBERTY STATE PARK
FERRY SLIP
RECONSTRUCTION

ARMY CORPS OF
ENGINEERS PERMIT
PLANS ONLY

JERSEY CITY
HUDSON COUNTY
STATE OF NEW JERSEY

811 PROTECT YOURSELF
ALL STATES REQUIRE NOTIFICATION
OF EXCAVATORS DESIGNERS OR
ANY PERSONS PREPARED TO
DISTURB THE EARTH'S SURFACE
ANYWHERE IN ANY STATE

Know what's below.
Call before you dig.
FOR STATE SPECIFIC DIRECT PHONE NUMBERS
VISIT: WWW.CALL811.COM

RED BANK OFFICE
Corporate Headquarters
331 Newman Springs Road
Suite 203
Red Bank, NJ 07701
Phone: 732.383.1550
Fax: 732.383.1984

ARMY CORPS OF ENGINEERS PERMIT PLANS			
SCALE: AS SHOWN	DATE: 06/08/16	DRAWN BY: AEO	CHECKED BY: RCM
PROJECT NUMBER: 14001865A	DRAWING NAME: MASER - TITLEBLOCK SMALL		
SHEET NUMBER: C1.6-3			

MATCHLINE 3

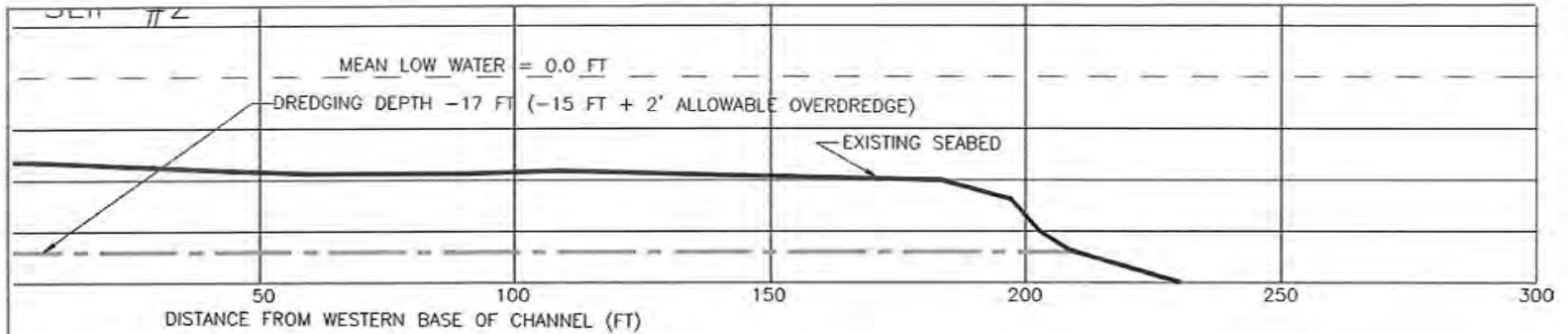

MATCHLINE 4

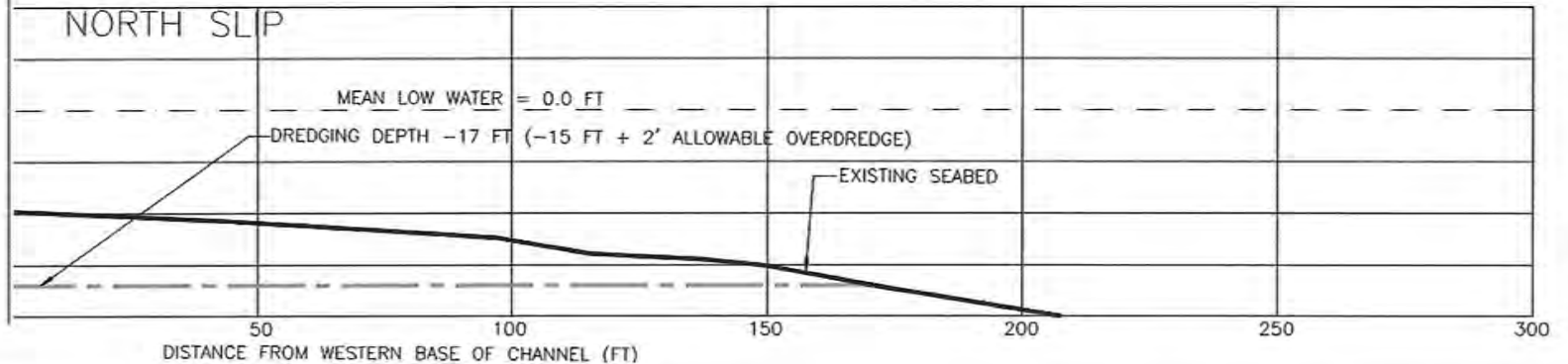
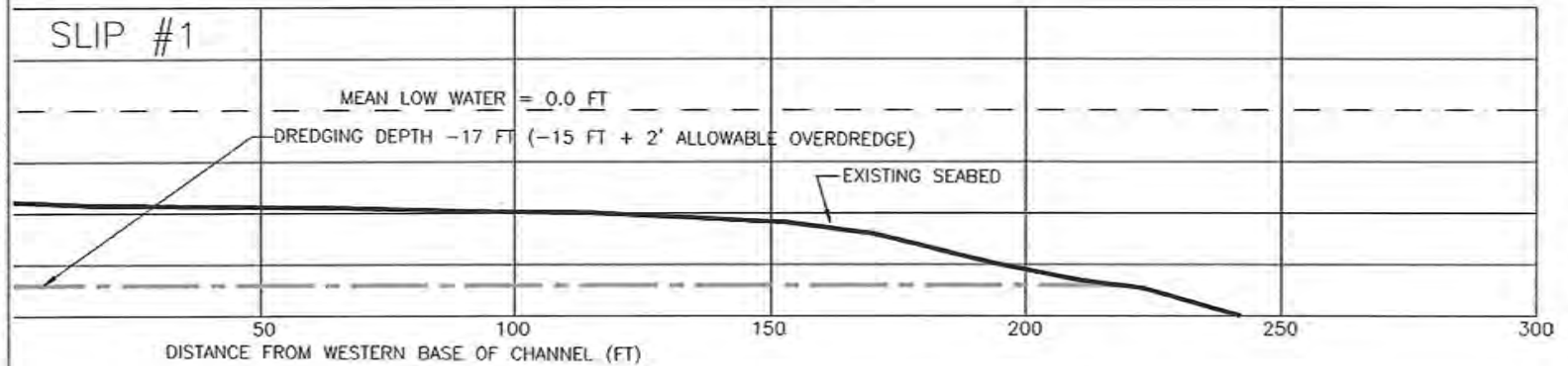

Figure 14 of 20



Customer Loyalty through Client Satisfaction
 www.maserconsulting.com

Engineers • Planners • Surveyors
 Landscape Architects • Environmental Scientists

State of N.J. Cert. of Authorization: 24GA27988500

Office Locations:

- Red Bank, NJ
- Clinton, NJ
- Hamilton, NJ
- Marmora, NJ
- Mt. Arlington, NJ
- Mt. Laurel, NJ
- Sterling, VA
- Norfolk, VA
- Albuquerque, NM
- Albany, NY
- Chestnut Ridge, NY
- Newburgh, NY
- Hawthorne, NY
- Lehigh Valley, PA
- Exton, PA
- Philadelphia, PA
- Tampa, FL
- Miami, FL
- Columbia, MD

Copyright © 2016 Maser Consulting P.A. All Rights Reserved. This drawing and all information contained herein is authorized for use only by the party for whom the services were provided or for whom it is prepared. This drawing may not be copied, revised, deleted, distributed or relied upon for any other purpose without the express written consent of Maser Consulting P.A.

REV	DATE	DRAWN BY	DESCRIPTION

LIBERTY STATE PARK
 FERRY SLIP
 RECONSTRUCTION

ARMY CORPS OF
 ENGINEERS PERMIT
 PLANS ONLY

JERSEY CITY
 HUDSON COUNTY
 STATE OF NEW JERSEY



PROTECT YOURSELF
 ALL STATES REQUIRE NOTIFICATION
 OF DCAVATORS, ENGINEERS, OR
 ANY PERSON PREPARING TO
 DISTURB THE EARTH'S SURFACE
 ANYWHERE IN ANY STATE

Know what's below,
 Call before you dig.
 FOR STATE SPECIFIC DIRECT PHONE NUMBERS
 VISIT: WWW.CALL811.COM

ARMY CORPS OF ENGINEERS PERMIT
 PLANS

SCALE AS SHOWN	DATE 06/08/16	DRAWN BY AEO	CHECKED BY RCM
-------------------	------------------	-----------------	-------------------

PROJECT NUMBER 1400185A	DRAWING NAME MASER - TITLEBLOCK SMALL
----------------------------	--

SHEET TITLE:

SHEET NUMBER:
C1.6-4



RED BANK OFFICE
 Corporate Headquarters
 311 Newman Springs Road
 Suite 203
 Red Bank, NJ 07701
 Phone: 732.383.1550
 Fax: 732.383.1584

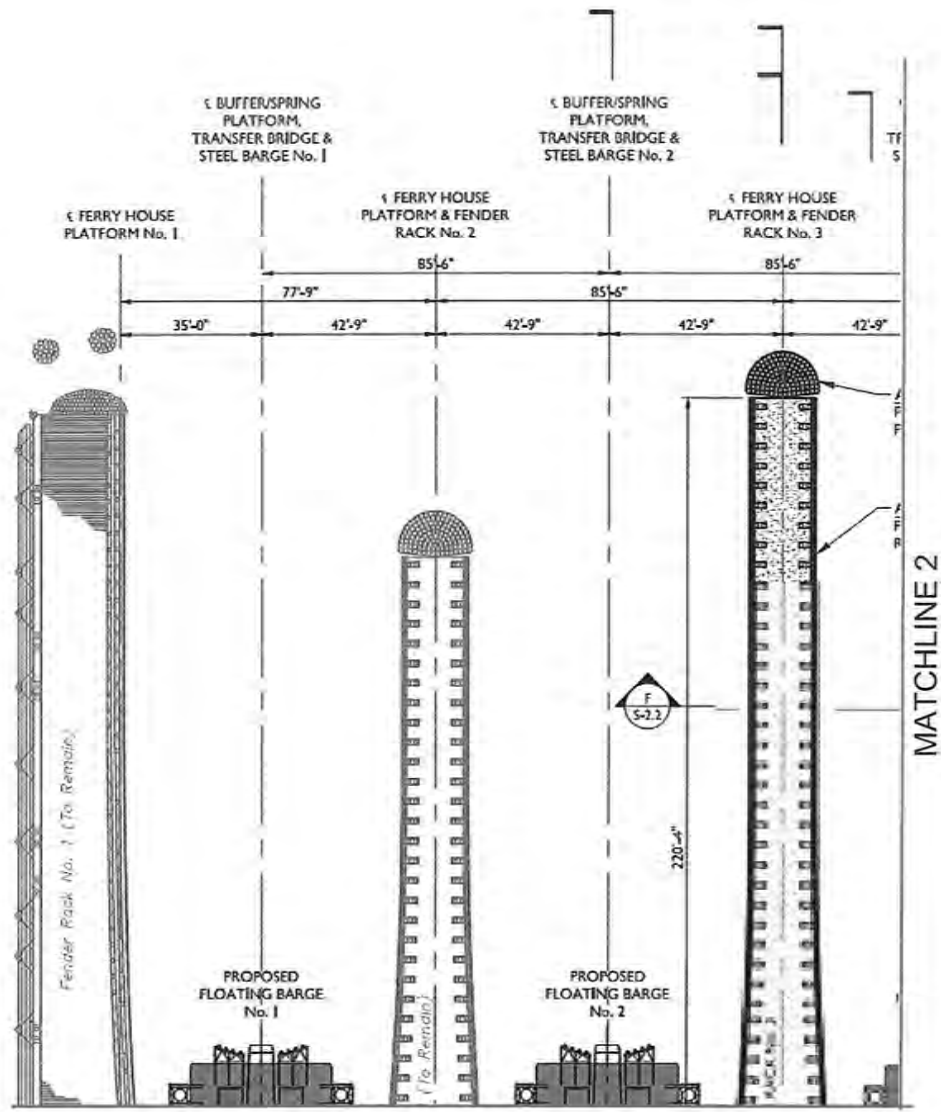

MATCHLINE 1

Figure 15 of 20



Customer Loyalty through Client Satisfaction
www.maserconsulting.com

Engineers ■ Planners ■ Surveyors
Landscape Architects ■ Environmental Scientists

State of N.J. Cert. of Authorization: 24GA27986500

Office Locations:

- Red Bank, NJ
- Albany, NY
- Clinton, NJ
- Chestnut Ridge, NY
- Hamilton, NJ
- Newburgh, NY
- Marmora, NJ
- Hawthorne, NY
- Mt. Arlington, NJ
- Lehigh Valley, PA
- Mc. Laurel, NJ
- Exton, PA
- Philadelphia, PA
- Sterling, VA
- Tampa, FL
- Norfolk, VA
- Miami, FL
- Albuquerque, NM
- Columbia, MD

Copyright © 2016 Maser Consulting P.A. All Rights Reserved. This drawing and all its information is confidential and intended for use only by the party for whom the services were rendered or to whom it is provided. This drawing may not be copied, revised, distributed or relied upon for any other project without the express written consent of Maser Consulting P.A.

REV	DATE	DRAWN BY	DESCRIPTION
-	-	-	-
-	-	-	-
-	-	-	-
-	-	-	-
-	-	-	-
-	-	-	-

LIBERTY STATE PARK
FERRY SLIP
RECONSTRUCTION

ARMY CORPS OF
ENGINEERS PERMIT
PLANS ONLY

JERSEY CITY
HUDSON COUNTY
STATE OF NEW JERSEY

811 PROTECT YOURSELF
ALL STATES REQUIRE NOTIFICATION
OF DIGGERS, DESIGNERS, OR
ANY PERSON PREPARING TO
DISTURB THE EARTH'S SURFACE
ANYWHERE IN ANY STATE

Know what's below.
Call before you dig.
FOR STATE SPECIFIC DIRECT PHONE NUMBERS
VISIT: WWW.CALL811.COM

RED BANK OFFICE
Corporate Headquarters
331 Newman Springs Road
Suite 203
Red Bank, NJ 07701
Phone: 732.383.1950
Fax: 732.383.1964

ARMY CORPS OF ENGINEERS PERMIT PLANS			
SCALE AS SHOWN	DATE 06/09/16	DRAWN BY AEO	CHECKED BY RCH
PROJECT NUMBER: 14001865A		DRAWING NAME: MASER - TITLEBLOCK SMALL	
SHEET TITLE:			
SHEET NUMBER:			S2.1-1

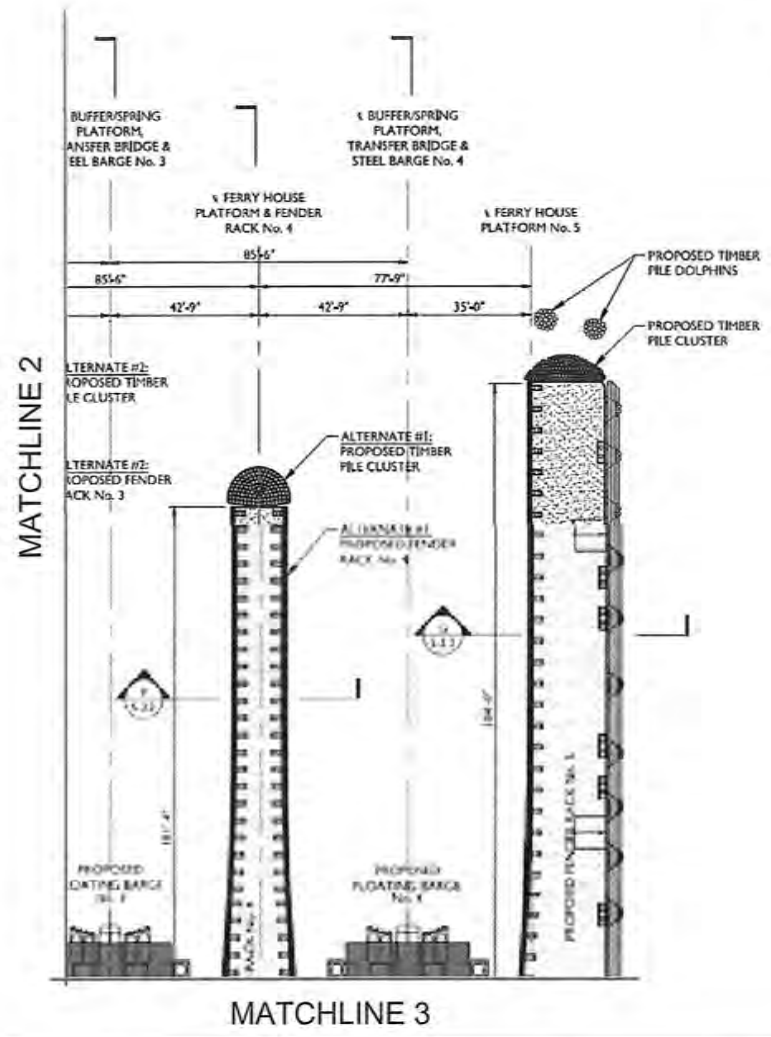

Figure 16 of 20

MASER CONSULTING P.A.

Customer Loyalty through Client Satisfaction
www.maserconsulting.com

Engineers ■ Planners ■ Surveyors
Landscape Architects ■ Environmental Scientists

State of N.J. Cert. of Authorization: 24GA27985500

Office Locations:

■ Red Bank, NJ	■ Albany, NY
■ Clinton, NJ	■ Chestnut Ridge, NY
■ Hamilton, NJ	■ Newburgh, NY
■ Marmora, NJ	■ Hawthorne, NY
■ Mt. Arlington, NJ	■ Lehigh Valley, PA
■ Mt. Laurel, NJ	■ Exton, PA
■ Sterling, VA	■ Philadelphia, PA
■ Norfolk, VA	■ Tampa, FL
■ Albuquerque, NM	■ Miami, FL
	■ Columbia, MD

Copyright © 2016 Maser Consulting P.A. All Rights Reserved. This drawing and all information contained herein is submitted for use only by the party for whom the services were contracted and where it is applied. This drawing may not be copied, revised, duplicated, distributed or used again for any other purpose without the express written consent of Maser Consulting P.A.

REV	DATE	DRAWN BY	DESCRIPTION
-	-	-	-
-	-	-	-
-	-	-	-
-	-	-	-
-	-	-	-
-	-	-	-

LIBERTY STATE PARK
FERRY SLIP
RECONSTRUCTION

ARMY CORPS OF
ENGINEERS PERMIT
PLANS ONLY

JERSEY CITY
HUDSON COUNTY
STATE OF NEW JERSEY

811

PROTECT YOURSELF
ALL STATES REQUIRE NOTIFICATION
OF EXCAVATORS, DESIGNERS OR
ANY PERSON PREPARING TO
DISTURB THE EARTH'S SURFACE
ANYWHERE IN ANY STATE

Know what's below.
Call before you dig.
FOR STATE SPECIFIC DIRECT PHONE NUMBERS
VISIT: WWW.CALL811.COM

RED BANK OFFICE
Corporate Headquarters
311 Newman Springs Road
Suite 203
Red Bank, NJ 07701
Phone: 732.383.1950
Fax: 732.383.1964

ARMY CORPS OF ENGINEERS PERMIT
PLANS

SCALE:	DATE:	DRAWN BY:	CHECKED BY:
AS SHOWN	06/08/16	AEO	RCM

PROJECT NUMBER: 14001865A
DRAWING NAME: MASER - TITLEBLOCK SMALL

SHEET NUMBER: S2.1-2

MATCHLINE 1

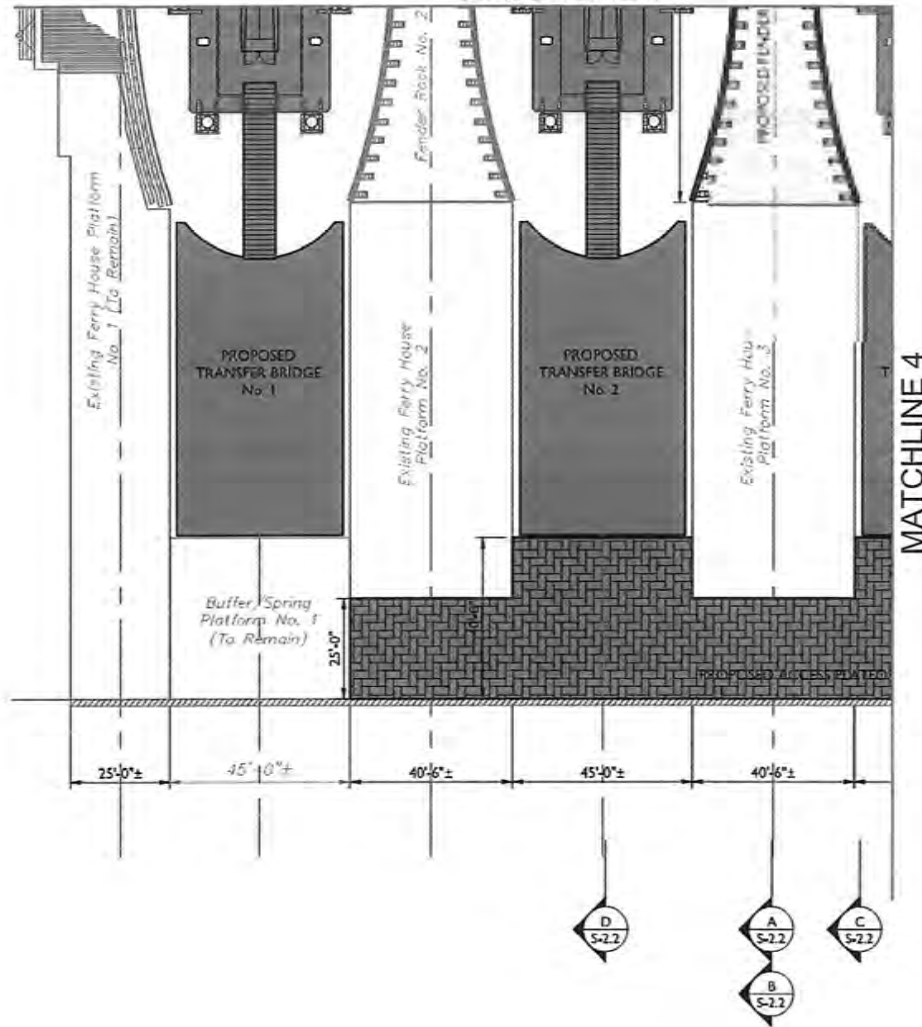

OVERALL STRUCTURAL
SCALE: 1/2" = 1'-0"

Figure 17 of 20



Customer Loyalty through Client Satisfaction
www.maserconsulting.com

Engineers ■ Planners ■ Surveyors
Landscape Architects ■ Environmental Scientists

State of N.J. Cert. of Authorization: 24GA27986500

Office Locations:

- Red Bank, NJ
- Clinton, NJ
- Hamilton, NJ
- Marmora, NJ
- Mt. Arlington, NJ
- Mc. Laural, NJ
- Sterling, VA
- Norfolk, VA
- Albuquerque, NM
- Albany, NY
- Chestnut Ridge, NY
- Newburgh, NY
- Hawthorne, NY
- Lehigh Valley, PA
- Exton, PA
- Philadelphia, PA
- Tampa, FL
- Miami, FL
- Columbia, MD

Copyright © 2016 Maser Consulting P.A. All Rights Reserved. This drawing and all its information contained herein is authorized for use only by the party for whom the services were rendered or to whom it is provided. This drawing may not be copied, revised, distributed or used again for any other purpose without the express written consent of Maser Consulting P.A.

REV	DATE	DRAWN BY	DESCRIPTION

LIBERTY STATE PARK
FERRY SLIP
RECONSTRUCTION

ARMY CORPS OF
ENGINEERS PERMIT
PLANS ONLY

JERSEY CITY
HUDSON COUNTY
STATE OF NEW JERSEY

811 PROTECT YOURSELF
ALL STATES REQUIRE NOTIFICATION
OF EXCAVATORS DESIGNERS OR
ANY PERSON PREPARING TO
DISTURB THE EARTH'S SURFACE
ANYWHERE IN ANY STATE

Know what's below.
Call before you dig.
FOR STATE SPECIFIC DIRECT PHONE NUMBERS
VISIT: WWW.CALL811.COM

RED BANK OFFICE
Corporate Headquarters
331 Newnam Springs Road
Suite 203
Red Bank, NJ 07701

Phone: 732.383.1650
Fax: 732.383.1984

ARMY CORPS OF ENGINEERS PERMIT PLANS			
SCALE:	DATE:	DRAWN BY:	CHECKED BY:
AS SHOWN	06/08/16	AEO	RCM
PROJECT NUMBER:	DRAWING NAME:		
14001865A	MASER - TITLEBLOCK SMALL		
SHEET TITLE:			
SHEET NUMBER:			
S2.1-3			

MATCHLINE 1

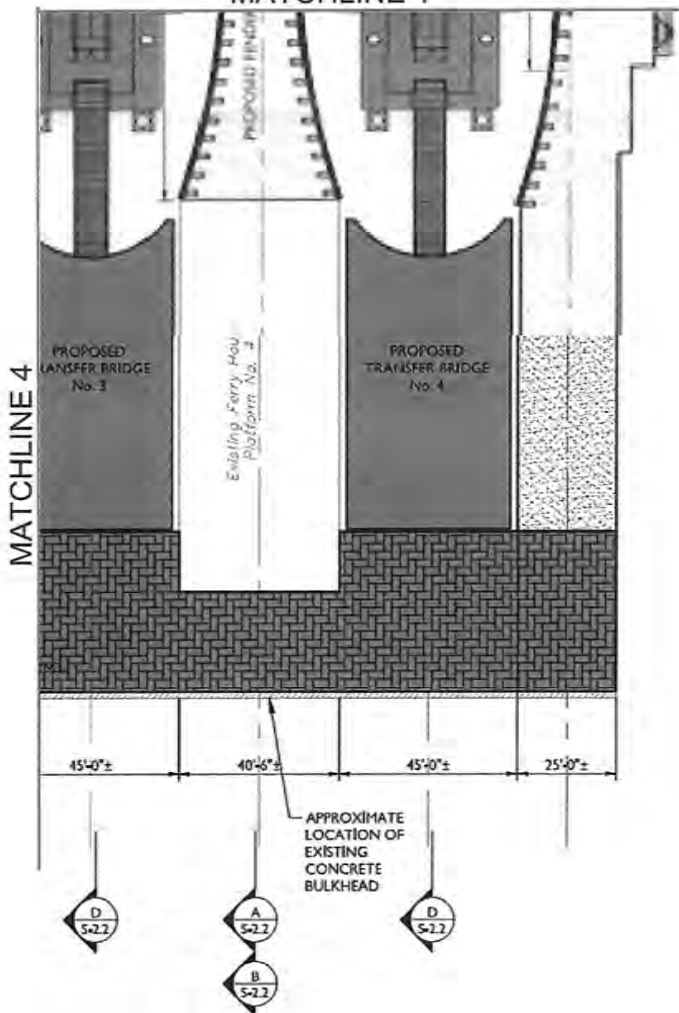

PLAN

NOTES:

1. CONTRACTOR MUST VERIFY ALL DIMENSIONS IN FIELD PRIOR TO SHOP DRAWINGS, FABRICATION, AND INSTALLATION.
2. ALL DIMENSIONS SHOWN ARE APPROXIMATED BASED ON THE EXISTING CONDITIONS DEVELOPED FROM THE FIELD SURVEY AND FROM ORIGINAL CONSTRUCTION DRAWINGS. DIMENSIONS SHALL ALL BE FIELD VERIFIED AND ADJUSTED AS REQUIRED TO PROVIDE THE INTENDED LAYOUT AS SHOWN ON THE DRAWINGS. ALL CONSTRUCTION SHALL MEET EXISTING ADJACENT FEATURES AND GRADES AS CLOSELY AS POSSIBLE TO CREATE A SEAMLESS TRANSITION FROM EXISTING CONDITIONS TO PROPOSED CONDITIONS.
3. DISTANCE OF PROPOSED CONSTRUCTION LIMIT TO FEDERAL CHANNEL = 425FT.
4. LENGTH AND WIDTH OF ALL (4) FLOATING BARGES IS 40'x40'.
5. ALL TRANSFER BRIDGES (4) TO BE 78'-5" LONG x 41'-4" WIDE.

- 14" DIA. TIMBER PILES = 15 TOTAL BLOWS PER PILE (389 PILES)
- 16" DIA. STEEL PILES = 144 TOTAL BLOWS PER PILE (345 PILES)

Figure 18 of 20



Customer Loyalty through Client Satisfaction
www.maserconsulting.com

Engineers ■ Planners ■ Surveyors
Landscape Architects ■ Environmental Scientists

State of N.J. Cert. of Authorization: 24GA27986500

Office Locations:

- Red Bank, NJ
- Albany, NY
- Clinton, NJ
- Chestnut Ridge, NY
- Hamilton, NJ
- Newburgh, NY
- Marmora, NJ
- Haworth, NY
- Mc. Arlington, NJ
- Lehigh Valley, PA
- Mc. Laurel, NJ
- Exton, PA
- Philadelphia, PA
- Sterling, VA
- Tampa, FL
- Norfolk, VA
- Miami, FL
- Albuquerque, NM
- Columbia, MD

Copyright © 2016 Maser Consulting P.A. All Rights Reserved. This drawing and all its information, content, notes and schedules for use only by the party for whom the services were intended or to whom it is provided. This drawing may not be copied, revised, distributed, stored or used in any way other than as intended by the original contractor of Maser Consulting P.A.

REV	DATE	DRAWN BY	DESCRIPTION

LIBERTY STATE PARK
FERRY SLIP
RECONSTRUCTION

ARMY CORPS OF
ENGINEERS PERMIT
PLANS ONLY

JERSEY CITY
HUDSON COUNTY
STATE OF NEW JERSEY

811 PROTECT YOURSELF
ALL STATES REQUIRE NOTIFICATION
OF EXCAVATORS, DESIGNERS, OR
ANY PERSON PREPARING TO
DISTURB THE EARTH'S SURFACE
ANYWHERE IN ANY STATE

Know what's below.
Call before you dig.
FOR STATE SPECIFIC DIRECT PHONE NUMBERS
VISIT: WWW.CALL811.COM

RED BANK OFFICE
Corporate Headquarters
331 Newman Springs Road
Suite 203
Red Bank, NJ 07701
Phone: 732.383.1550
Fax: 732.383.1984

ARMY CORPS OF ENGINEERS PERMIT PLANS			
SCALE AS SHOWN	DATE 06/08/16	DRAWN BY AEO	CHECKED BY RCM
PROJECT NUMBER: 14001865A	DRAWING NAME: MASER - TITLEBLOCK SHALL		
SHEET NUMBER: S2.1-4			

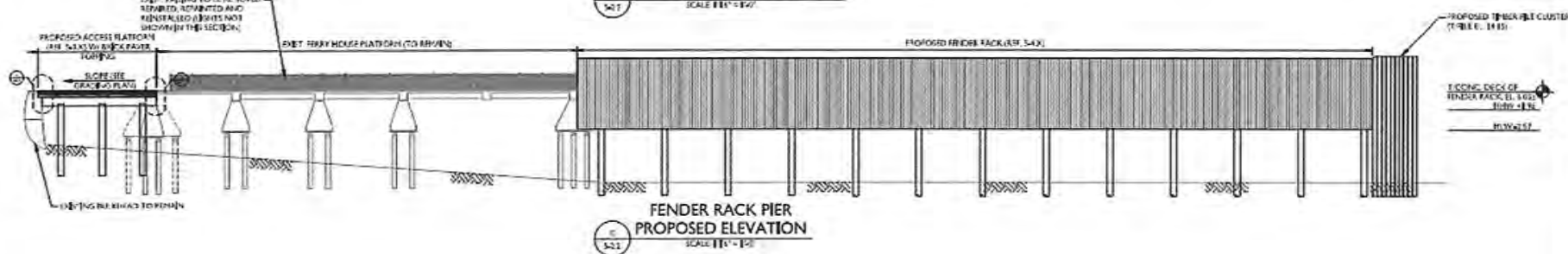
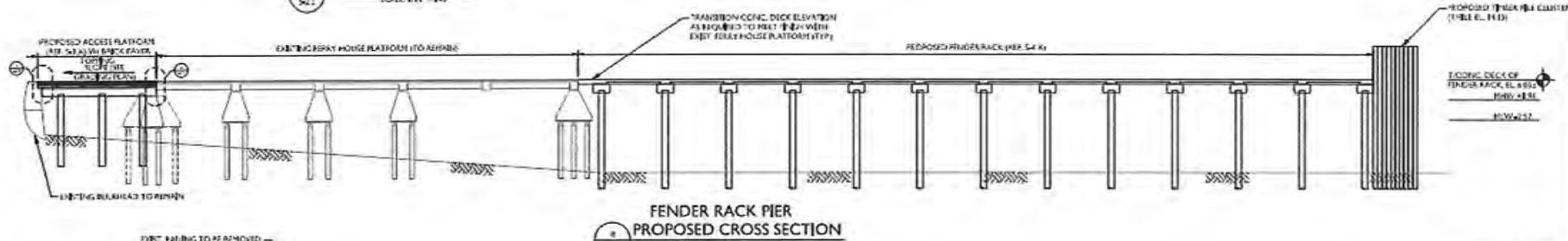
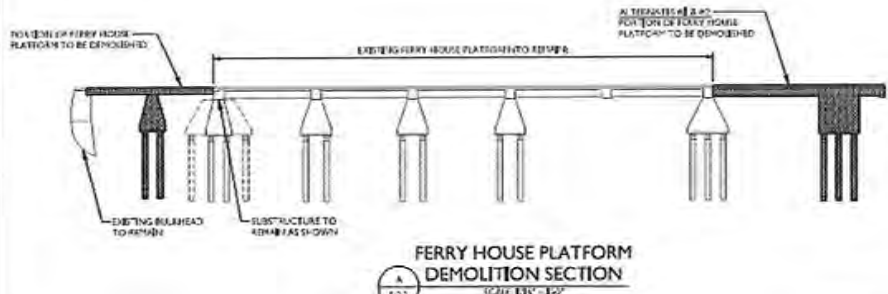

Figure 19 of 20

MASER
CONSULTING P.A.

Customer Loyalty through Client Satisfaction
www.maserconsulting.com

Engineers ■ Planners ■ Surveyors
Landscape Architects ■ Environmental Scientists

State of N.J. Cert. of Authorization: 24GA27986500

Copyright © 2016 Maser Consulting P.A. All Rights Reserved. This drawing and all information contained herein is authorized for use only by the party for whom the services were contracted or to whom it is loaned. This drawing may not be copied, re-used, disclosed, distributed or referred to in any other manner without the express written consent of Maser Consulting P.A.

Office Locations:

- Red Bank, NJ
- Clinton, NJ
- Hamilton, NJ
- Marmora, NJ
- Mt. Arlington, NJ
- Mt. Laurel, NJ
- Sterling, VA
- Norfolk, VA
- Albuquerque, NM
- Albany, NY
- Chestnut Ridge, NY
- Newburgh, NY
- Hawthorne, NY
- Lehigh Valley, PA
- Exton, PA
- Philadelphia, PA
- Tampa, FL
- Miami, FL
- Columbia, MD

REV	DATE	DRAWN BY	DESCRIPTION
-	-	-	-
-	-	-	-
-	-	-	-
-	-	-	-
-	-	-	-
-	-	-	-
-	-	-	-

LIBERTY STATE PARK
FERRY SLIP
RECONSTRUCTION

ARMY CORPS OF
ENGINEERS PERMIT
PLANS ONLY

JERSEY CITY
HUDSON COUNTY
STATE OF NEW JERSEY

PROTECT YOURSELF
ALL STATES REQUIRE NOTIFICATION
OF EXCAVATORS, DESIGNERS, OR
ANY PERSON PREPARING TO
DISTURB THE EARTH'S SURFACE
ANYWHERE IN ANY STATE

Know what's below.
Call before you dig.
FOR STATE SPECIFIC DIRECT PHONE NUMBERS
VISIT: WWW.CALL811.COM

RED BANK OFFICE
Corporate Headquarters
331 Newman Springs Road
Suite 203
Red Bank, NJ 07701
Phone: 732.383.1550
Fax: 732.383.1594

ARMY CORPS OF ENGINEERS PERMIT PLANS			
SCALE	DATE	DRAWN BY	CHECKED BY
AS SHOWN	06/08/16	AEO	RCM
PROJECT NUMBER:	DRAWING NAME:		
14001865A	MASER - TITLEBLOCK SMALL		
SHEET TITLE:			
SHEET NUMBER: S2.2-1			

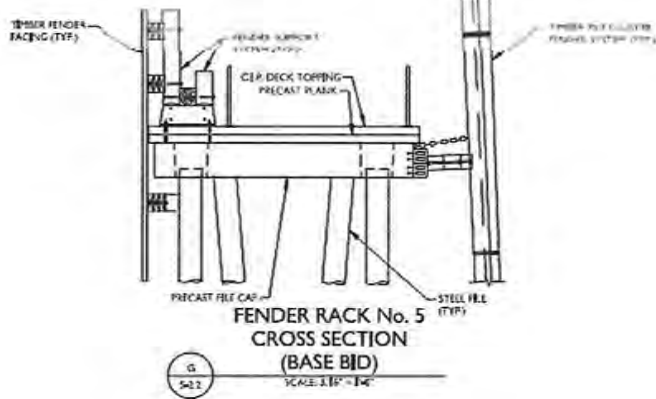
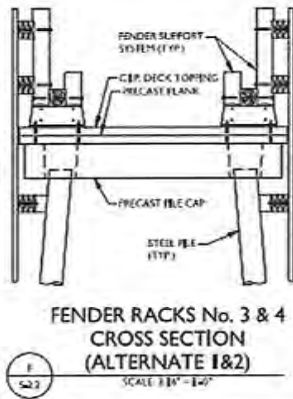
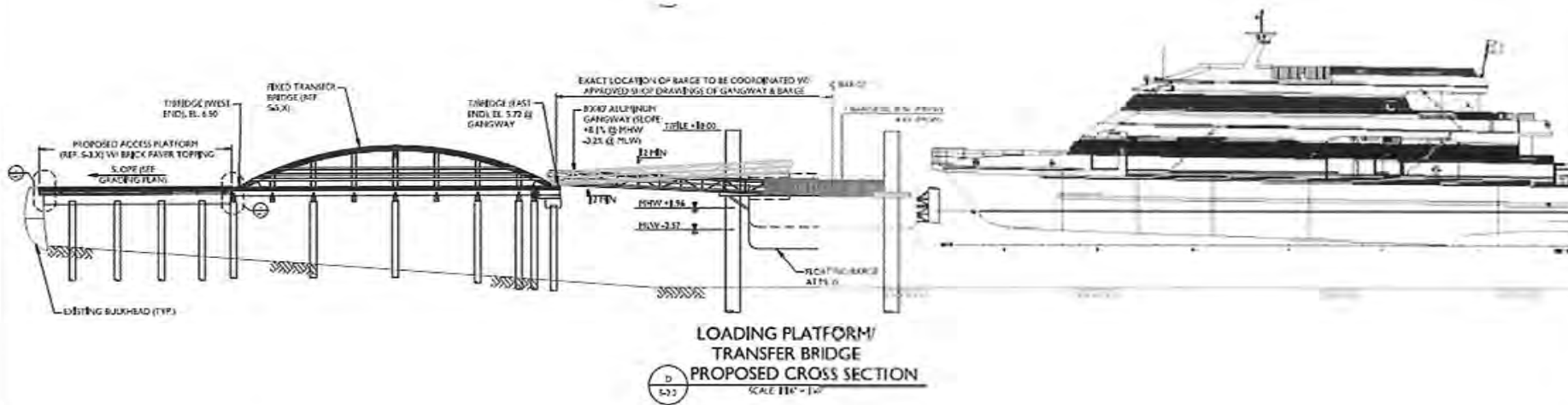

Figure 20 of 20



Customer Loyalty through Client Satisfaction
www.maserconsulting.com

Engineers ■ Planners ■ Surveyors
Landscape Architects ■ Environmental Scientists

State of N.J. Cert. of Authorization: 24GA27986500

Copyright © 2016 Maser Consulting P.A. All Rights Reserved. This drawing and all information contained herein is furnished for use only by the party for whom the services were contracted or to whom it is directed. This drawing may not be copied, reprinted, distributed or used again for any other purpose without the express written consent of Maser Consulting P.A.

Office Locations:

- Red Bank, NJ
- Clinton, NJ
- Hamilton, NJ
- Marmora, NJ
- Mt. Arlington, NJ
- Mt. Laurel, NJ
- Sterling, VA
- Norfolk, VA
- Albuquerque, NM
- Albany, NY
- Chestnut Ridge, NY
- Newburgh, NY
- Hawthorne, NY
- Lehigh Valley, PA
- Exton, PA
- Philadelphia, PA
- Tampa, FL
- Miami, FL
- Columbia, MD

REV	DATE	DRAWN BY	DESCRIPTION

LIBERTY STATE PARK
FERRY SLIP
RECONSTRUCTION

ARMY CORPS OF
ENGINEERS PERMIT
PLANS ONLY

JERSEY CITY
HUDSON COUNTY
STATE OF NEW JERSEY

PROTECT YOURSELF
ALL STATES REQUIRE NOTIFICATION OF EXCAVATORS, DESIGNERS, OR ANY PERSON PREPARING TO DISTURB THE EARTH'S SURFACE ANYWHERE IN ANY STATE.

Know what's below.
Call before you dig.
FOR STATE SPECIFIC DIRECT PHONE NUMBERS VISIT: WWW.CALL811.COM

RED BANK OFFICE
Corporate Headquarters
331 Newman Springs Road
Suite 203
Red Bank, NJ 07701
Phone: 732.383.1950
Fax: 732.383.1984

ARMY CORPS OF ENGINEERS PERMIT PLANS			
SCALE	DATE	DRAWN BY	CHECKED BY
AS SHOWN	05/08/16	AEO	RCH
PROJECT NUMBER:	DRAWING NAME:		
14001855A	MASER - TITLEBLOCK SMALL		
SHEET TITLE			
SHEET NUMBER:			
S2.2-2			